



4G Solar-powered Perimeter Sensing Camera User Manual

Version: V1.0
Date: 2026-04-24

Chapter 1. Introduction.....	4
1.1 Copyright Statement.....	4
1.2 Safety Instruction.....	4
1.3 Revision History.....	5
Chapter 2. Product Description.....	6
2.1 Product Overview.....	6
2.2 Hardware Overview.....	7
2.3 Installation Guide.....	8
Chapter 3. Live Video.....	16
Chapter 4. Explorer.....	19
Chapter 5. Media.....	21
Video.....	21
Image.....	22
Audio.....	26
Audio.....	26
Audio File Management.....	27
Chapter 6. Network.....	28
Cellular.....	28
WLAN.....	31
HTTPS.....	35
RTSP.....	35
Chapter 7. Storage.....	37
Storage Management.....	37
Snapshot Settings.....	38
Chapter 8. Event.....	40
Motion Detection.....	40
Noise Detection.....	46
Scheduled Task.....	51
Exception.....	55
Tamper Detection.....	55
SD Card Exception.....	60
Battery Status Alert.....	63

Data Usage Alert.....	66
PIR Overtrigger Alert.....	70
One-Click Disarm.....	73
Alarm Settings.....	76
Alarm Server.....	76
Email.....	79
Chapter 9. System.....	81
Work Mode.....	81
System Setting.....	82
System Info.....	82
Date&Time.....	83
Interfaces.....	84
Battery System.....	85
GPS.....	86
Remote Management.....	88
Security.....	90
User.....	90
Security Service.....	93
Certificate Management.....	93
About.....	96
Maintenance.....	97
System Maintenance.....	97
Chapter 10. Services.....	101

Chapter 1. Introduction

Thank you for purchasing our product. If there is any question or request, please do not hesitate to contact your dealer.

This manual may contain several technically incorrect places or printing errors, and the content is subject to change without notice. The updates will be added into the new version of this manual. We will readily improve or update the products or procedures described in the manual.

This Manual explains how to use and manage Milesight 4G Solar-powered Traffic Sensing Camera. Please read this manual carefully before the operation and retain it for future reference.

1.1 Copyright Statement

This manual may not be reproduced in any form or by any means to create any derivative such as translation, transformation, or adaptation without the prior written permission of Xiamen Milesight IoT Co., Ltd (Hereinafter referred to as Milesight).

Milesight reserves the right to change this manual and the specifications without prior notice. The latest specifications and user documentation for all Milesight products are available on our official website <https://www.milesight.com/security/>

1.2 Safety Instruction

These instructions are intended to ensure that user can use the product correctly to avoid danger or property loss. The precaution measures are divided into “Warnings” and “Cautions”

Warnings: Serious injury or death may be caused if any of these warnings is neglected.

- This installation must be conducted by a qualified service person and should strictly comply with the electrical safety regulations of the local region
- To avoid risk of fire and electric shock, do keep the product away from rain and moisture before installed.
- Do not touch components such as heat sinks, power regulators, and processors, which may be hot
- Please make sure the plug is firmly inserted into the power socket

- If the product does not work properly, please contact your dealer. Never attempt to disassemble the camera by yourself

Cautions: Injury or equipment damage may be caused if any of these cautions are neglected.

- Make sure that the power supply voltage is correct before using the camera
- Do not store or install the device in extremely hot or cold temperatures, dusty or damp locations, and do not expose it to high electromagnetic radiation
- Only use components and parts recommended by manufacturer
- Do not drop the camera or subject it to physical shock
- To prevent heat accumulation, do not block air circulation around the camera
- Laser beams may damage image sensors. The surface of image sensors should not be exposed to where a laser beam equipment is used
- Use a blower to remove dust from the lens cover
- Use a soft, dry cloth to clean the surface of the camera. Stubborn stains can be removed using a soft cloth dampened with a small quantity of detergent solution, then wipe dry
- Do not use volatile solvents such as alcohol, benzene or thinners as they may damage the surface finishes
- Save the package to ensure availability of shipping containers for future transportation

1.3 Revision History

Table 1.

Version	Revision Content	Release Date
V1.0	First release	April 2026

Chapter 2. Product Description

2.1 Product Overview

The **4G Solar-powered Perimeter Sensing Camera** is a cutting-edge security solution designed for high-precision perimeter protection in challenging environments. By integrating 4G/Wi-Fi connectivity, advanced AOV (Always-on Video) technology, and multi-dimensional sensing, it eliminates the need for complex cabling while providing robust, AI-filtered detection. Featuring a **1/1.8" large sensor**, the camera delivers superior **4MP@5fps** video streams rather than simple snapshots, ensuring comprehensive evidence collection even in low-light conditions.

AOV + PIR Detection & AI Filtering

To adapt to diverse scenarios, the camera supports **PIR and AOV + PIR dual modes**. Users can choose pure PIR for extreme power saving or AOV+PIR for enhanced daytime monitoring. With a detection range of up to **30m** and **AI secondary filtering**, the system significantly reduces false alarms, ensuring that only genuine threats trigger an alert.

Versatile Working Modes

The device offers three flexible power-management modes to balance performance and longevity:

- **ActiveGuard Mode:** Combines PIR and AOV for continuous, high-intensity perimeter sensing.
- **EcoSnap Mode:** Features scheduled snapshots and exception-triggered alerts with remote wake-up support.
- **Standby Mode:** Maintains ultra-low power consumption while remaining ready for instant remote wake-up.

Working Mode	PIR	AOV	Scheduled Image	Exception Event	Remote Wake-up
ActiveGuard Mode	✓	✓	✓	✓	✓
EcoSnap Mode	×	×	✓	✓	✓
Standby Mode	×	×	×	✓	✓

Sustainable Solar Power & Ultra-Low Consumption

Engineered for off-grid reliability, the camera boasts an industry-leading low-power design (**38mW** in PIR standby). When paired with a **555Wh battery**, it can operate for up to **535 days** during continuous overcast weather (Standby Mode). By integrating with **45W or 100W solar panels** (S45/S100 series), the system achieves 24/7 autonomous operation, making it ideal for remote or infrastructure-free locations.

Multi-Dimensional Sensing & High Compatibility

Beyond visual monitoring, the camera is a hub of environmental intelligence. It integrates **GPS, temperature, sound, and installation/drop sensors** for holistic situational awareness. Data can be seamlessly transmitted via **HTTP(S), MQTT(S), or SMTP** to third-party platforms, supporting rich alarm linkages including snapshots, short video clips (2~5s), and audio alerts via external speakers.

Enterprise-Grade Management & Security

Designed for large-scale deployment, the camera supports a unified management platform for **batch configuration and remote maintenance**. To ensure data integrity, it employs a multi-layered security architecture, including **strong password policies, certificate management, and encrypted SD card file systems**, fully complying with **EU GDPR** privacy standards.

2.2 Hardware Overview

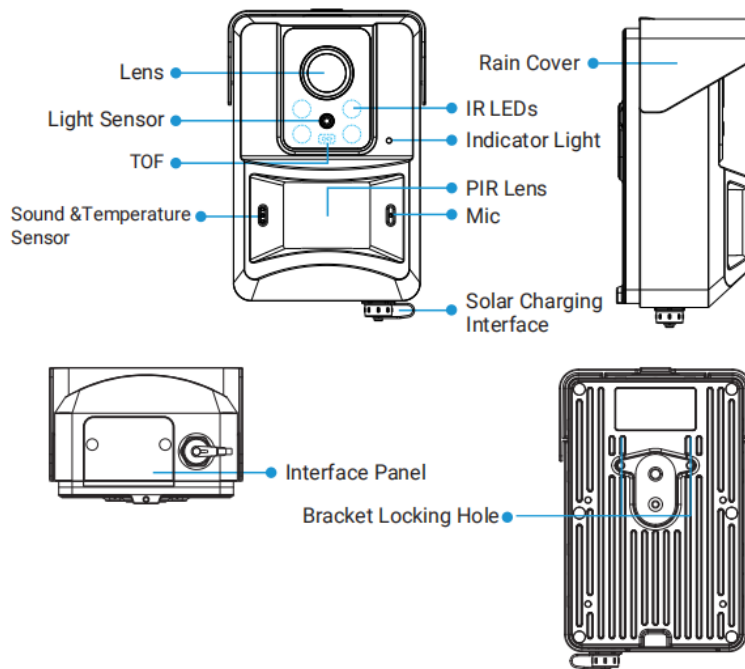

Note: The Positive Terminal of the Solar Panel Cable needs to be connected to the Negative Terminal of the solar panel, and the Negative Terminal needs to be connected to the Positive Terminal of the solar panel.

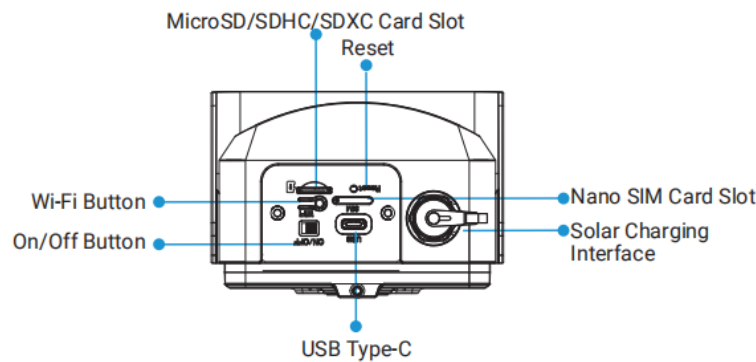

2.3 Installation Guide

Step 1: Loosen the screws of Interface Panel and remove the cover. And remove the Solar Charging Interface cover.

Step 2: Use the SIM Card Ejector Tool to remove the SIM card tray, and then install the SIM Card and SD Card.

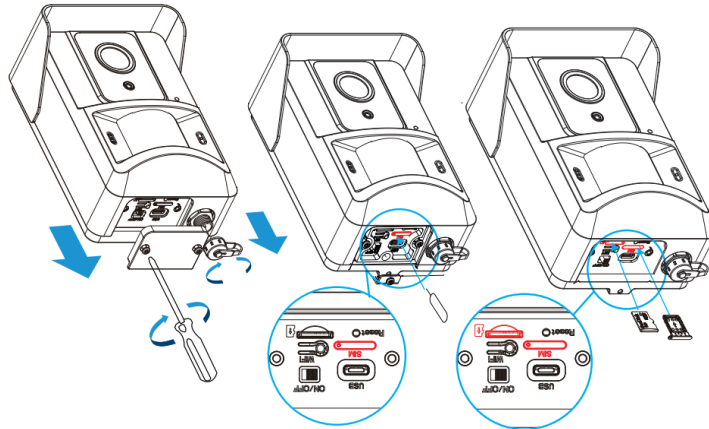

Step 3: Switch the power to ON.

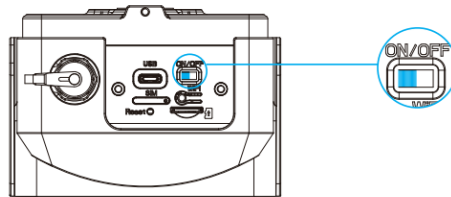

Note:

1. During device startup, the green indicator blinks slowly (1s intervals). Once SOC and Wi-Fi are initialized, the indicator turns solid green to enter configuration mode. The AP will turn off automatically after 5 minutes of no page interaction, and the indicator will turn off.
2. To reset the device, press and hold the reset button for 5 seconds; the green indicator blinks quickly (0.5s intervals) while holding. After release, slow blinking indicates resetting, and solid green means reset completed.
3. To enable Wi-Fi manually:

If the device is in sleep mode, press the Wi-Fi button; the green indicator blinks (1s intervals) until SOC and Wi-Fi start, then turns solid green.

If the device is already awake, press the Wi-Fi button; the indicator turns solid green when Wi-Fi starts. If a Wi-Fi error occurs, the indicator turns off.

The AP will turn off automatically after 5 minutes of no interaction, or manually by pressing the Wi-Fi button again, which turns off the indicator.

4. During normal sleep or operation, the indicator remains off for stealth and low power consumption.

Step 4: Use mobile devices or laptop to connect to the device's Wi-Fi. The Wi-Fi name is SC411_xxxxxx (xxxxxx is the last six bits of the MAC address).

Step 5: Enter the IP address 192.168.1.1 in the browser to log in to the web page of the device and configure the device.

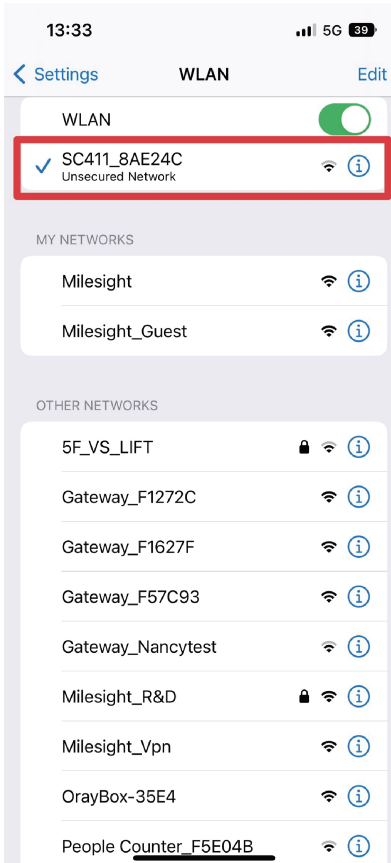

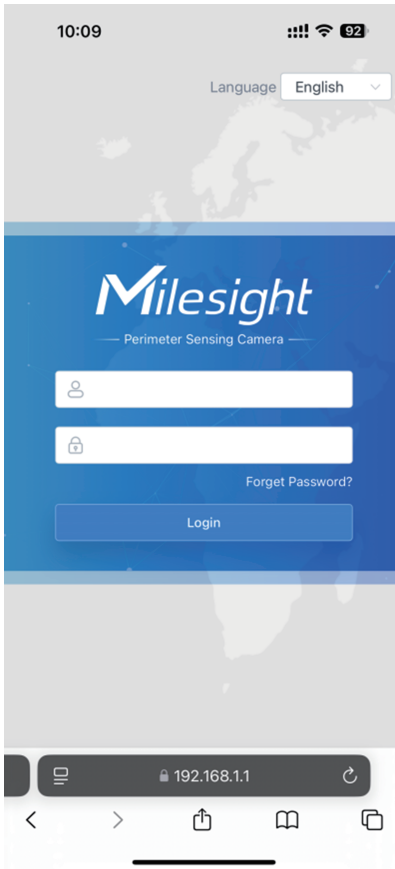

Step 6: Cover back the Interface Panel and fix the screws.

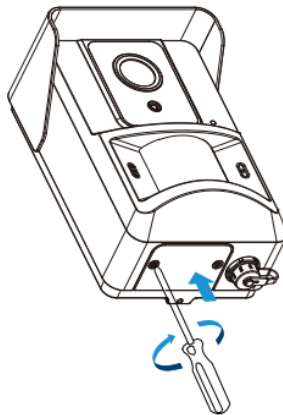

Step 7: Loosen the locking knob on the bracket, and remove the ball head and the base of the bracket.

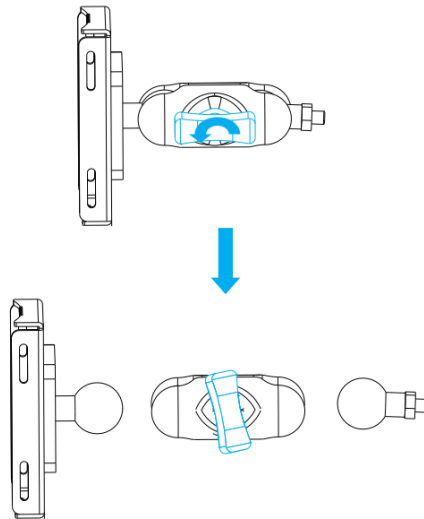

Step 8: Use the bracket screws to secure the ball head to the camera.

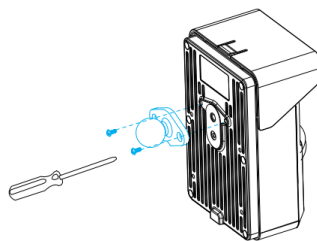

Step 9: Fix the base of the bracket in the position where the device is intended to be installed.

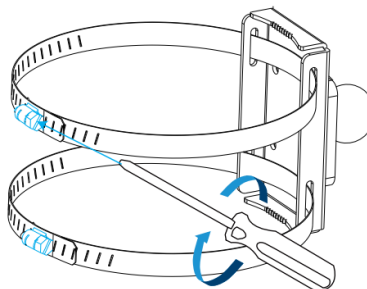

Note:

1. The recommended installation height is **2.1 m to 4 m**.
2. The optimal installation height is **2.1 m** with a tilt angle of **12°**. At this height and angle, the best performance can be achieved, as shown in the figure below.
3. To ensure precise detection, you can refer to the **real-time Pitch and Roll angles** displayed in the **Live Video** status panel. This allows you to calibrate the camera's

orientation accurately during installation to achieve the optimal 12° tilt and horizontal level, ensuring the PIR detection zone is perfectly aligned.

PIR Trigger Range

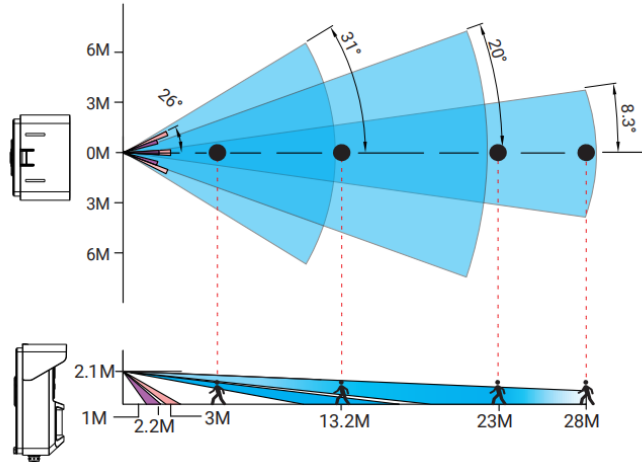

Step 10: After confirming the approximate direction, use the locking knob to connect the bracket base and the camera together.

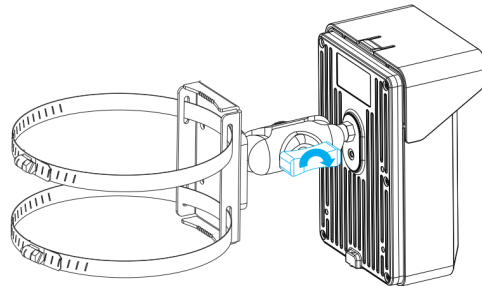

Note:

You can check the device's horizontal and tilt angles via Live Video. It is recommended to keep the horizontal angle at 0° , and estimate the tilt angle according to the image in Step 9.

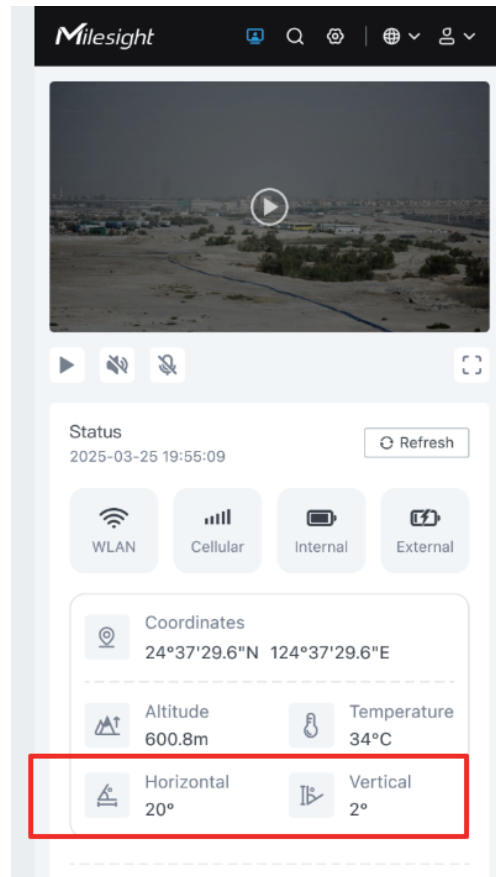

Step 11: Connect the solar panel to the Solar Charging Interface.

Note:

1. The Solar Panel Modules are optional.
2. The device has battery inside, when the solar power supply is insufficient, it can be powered by battery; When the battery is low, it can be charged using USB Type-C.

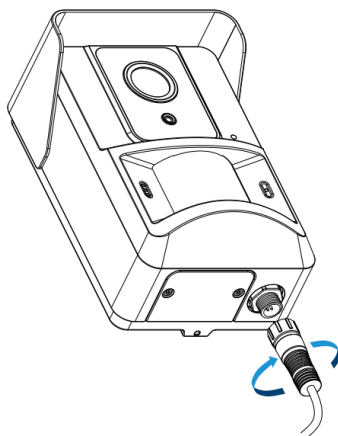

Cable Connection

Section A: Cable Interface for S100 Solar Panel Modules (S100B96/S100B55)

Cable: Solar Power System Cable

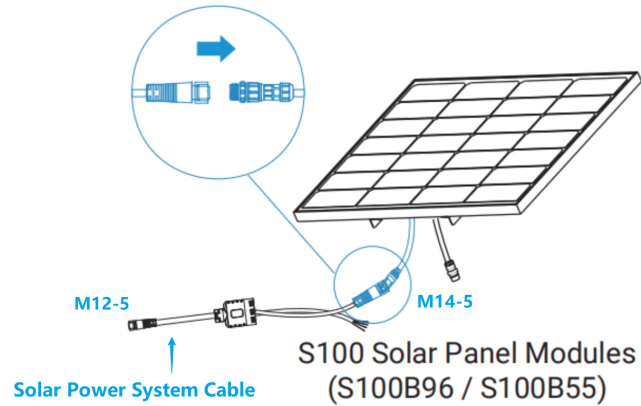

Section B: Cable Interface for S45 Solar Panel

Cable: Solar Power System Cable + Solar Panel Cable

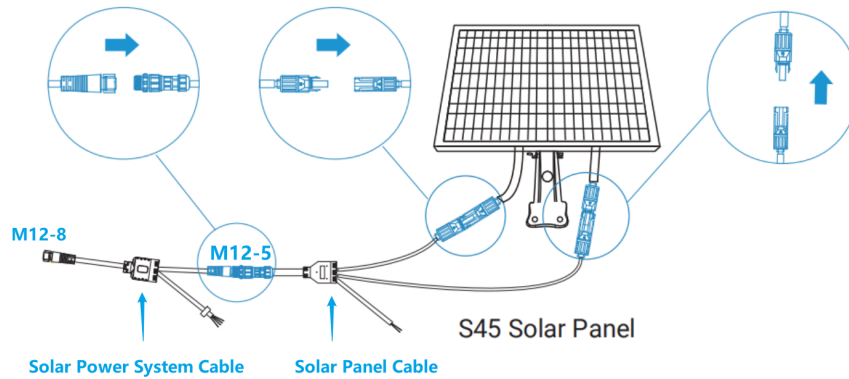

Chapter 3. Live Video

After logging in the network camera web GUI successfully, user is allowed to view live video as follows.

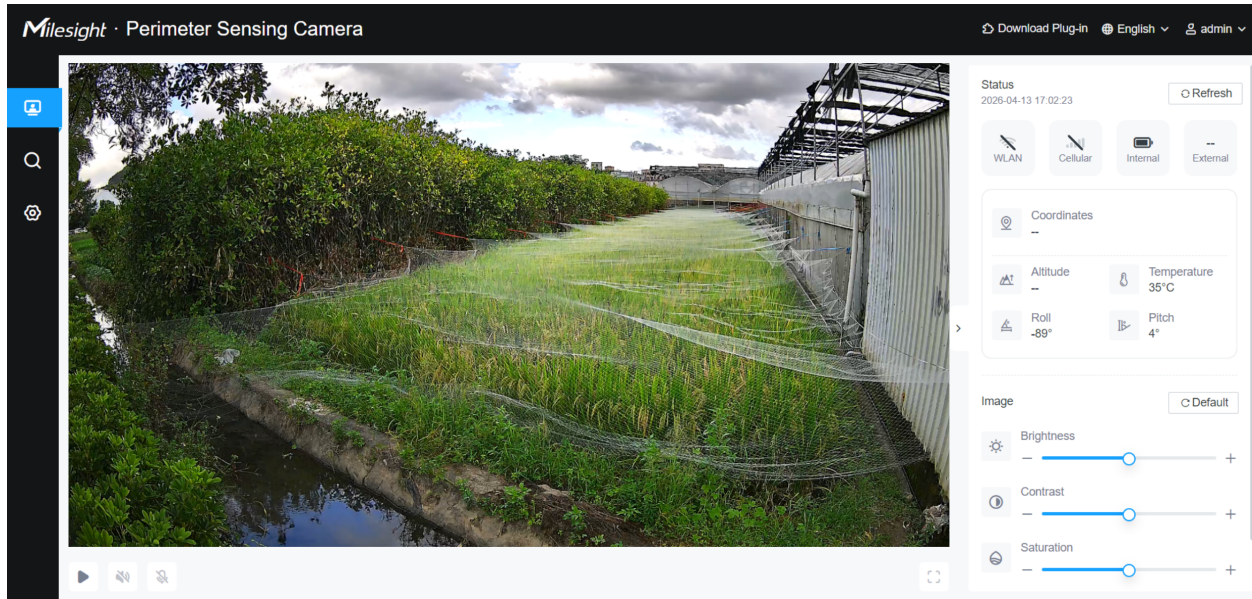



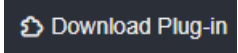

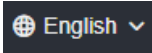
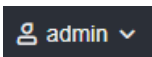



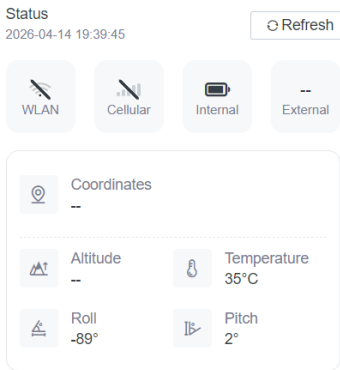







Table 2. Description of the buttons

No.	Parameter	Description
1	 Live Video	Click to access the live view page.
2	 Explorer	Click to access the explorer page.
3	 Settings	Click to access the configuration page.
4		To enhance the video preview quality, you can download and install the Mplayer video plug-in. This plug-in is designed to provide a smoother and more reliable video playback experience.  Note: This plug-in is only compatible with Windows systems.

No.	Parameter	Description
5		Click to select system language.
6		Display the user name and click to logout.
7	 Stop/Play	Starts or pauses the live video stream.
8		Mute on/Mute off the local audio.
9		Enables two-way talk (Start Talking/Stop Talking).
10	 Full Screen	Click to display images at full-screen.
11		<p>Update Time: The timestamp of the last data retrieval.</p> <p>Power Status: Icons for Internal and External Battery levels. A charging logo appears when power is connected.</p> <p>Signal Strength: * Cellular: Shows signal bars and dBm value (e.g., -60 dBm).</p> <ul style="list-style-type: none"> • WLAN: Shows connection status and signal quality. <p>Environment & Orientation:</p> <ul style="list-style-type: none"> • GPS: Latitude, Longitude, and Altitude. • Temperature: Internal device temperature (Updated every 1 minute). • Gyroscopic Data:Roll (Horizontal tilt) and Pitch (Vertical tilt) displayed in degrees (°). <p>[Refresh] Button: Click to manually fetch the latest status data from the hardware sensors (especially useful for re-calibrating angles during installation).</p>

No.	Parameter	Description
12		Brightness: Adjust the Brightness of the scene.
		Contrast: Adjust the color and light contrast.
		Saturation: Adjust the Saturation of the image. Higher Saturation makes colors appear more "pure" while lower one appears more "wash-out".
		Sharpness: Adjust the Sharpness of image. Higher Sharpness sharps the pixel boundary and makes the image looks "more clear".
		Default: Restore brightness, contrast and saturation to default settings.

Chapter 4. Explorer

The Explorer page allows you to search, view, and download recorded videos and snapshots stored on the SD card or NAS.

 **Note:**

1. Ensure an SD card is inserted to view files.
2. **DO NOT** insert or remove the SD card while the device is powered on to avoid data corruption.
3. Files can also be accessed via FTP using the format: ftp://username:password@DeviceIP.

Use the following filters to locate specific files. After setting the criteria, click **[Search]** to display the results (up to **8,000** records per search).

Table 3. Description of the buttons

Parameters	Function Introduction	Options
Main Type	Filter by the primary media format.	All , Record (Video), Snapshot (Image).
File Type	Filter files based on the trigger event.	If Record is selected: All, Motion Detection, Noise Detection. If Snapshot is selected: All, Motion Detection, Noise Detection, Scheduled Task.
Start / End Time	Define the time range for the search.	YYYY-MM-DD HH:MM:SS

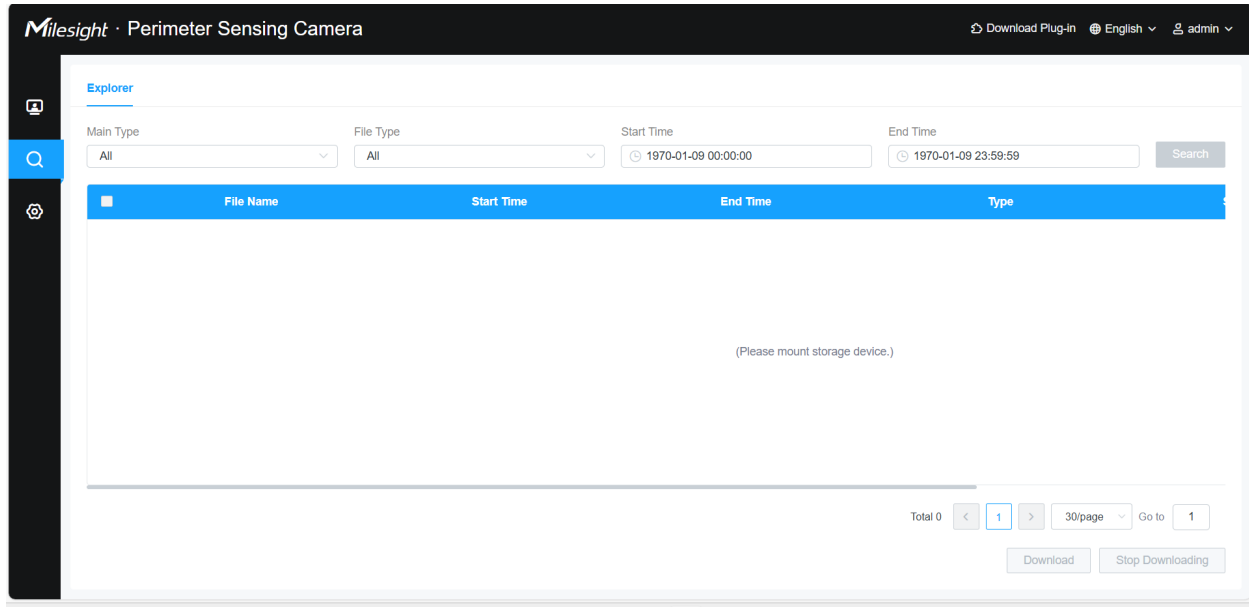

Once a search is performed, the files will be displayed with the following details:

- **File Name:** Automatically generated based on the timestamp and event type.
 - **Record Format:**YYYYMMDDHHMMSS_EventType.mp4 (e.g., 20240102104045_MotionDetection.mp4)
 - **Snapshot Format:**YYYYMMDDHHMMSS_EventType_Number.jpg (e.g., 20240102104045_MotionDetection_1.jpg)
- **Type:** Displays the specific trigger (Motion Detection, Noise Detection, or Scheduled Task).
- **Start / End Time:** Indicates the exact duration of the video clip or the capture time of the snapshot.
- **Size:** Displays the file size (e.g., in KB or MB).
- **Operation:** Use the **[Download]** button to save files to your local computer, or **[Stop]** to cancel an ongoing download.

Chapter 5. Media

Video

[Primary Stream]:

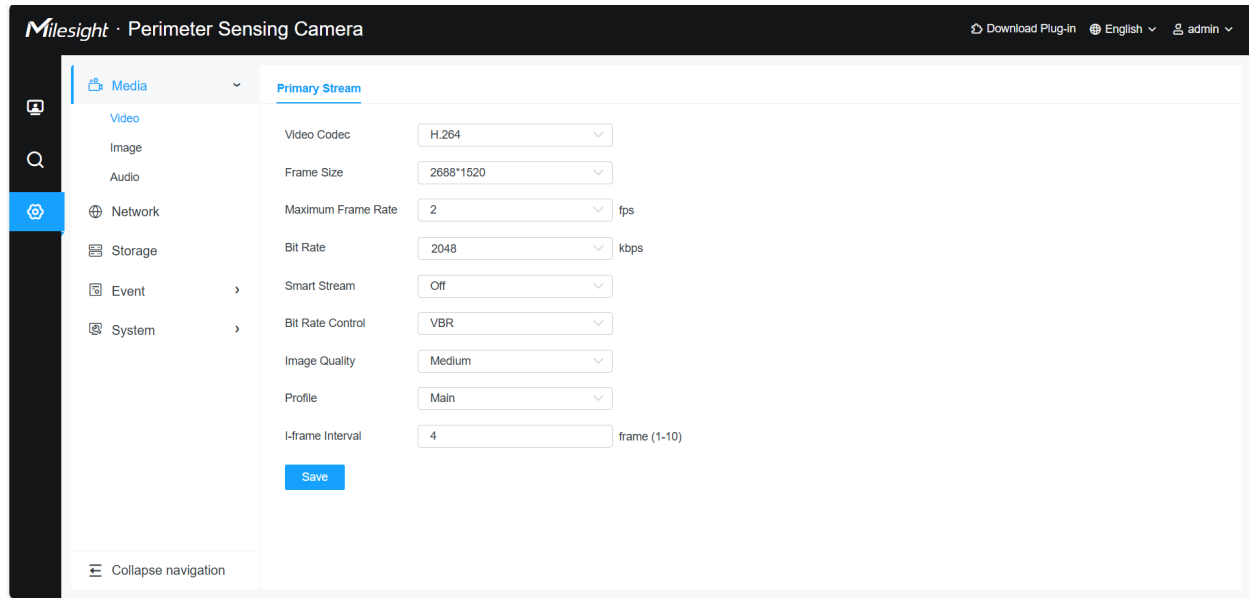

Table 4. Description of the buttons

Parameters	Function Introduction
Video Codec	H.265/H.264 are available.
Frame Size	Options include 4M (2688*1520), 3M (2304*1296), 1080p (1920*1080), 720p (1280*720).
Maximum Frame Rate	Maximum refresh rate per second. The supported range is 1-5 frames per second (fps).
Bit Rate	Transmitting bits of data per second. Set the bitrate to 16~6144 Kbps. The higher value corresponds to the higher video quality, and the higher bandwidth is required as well.

Parameters	Function Introduction
Smart Stream	<p>Smart Stream is an advanced video compression technology (H.265+) designed to optimize resource usage. Optional to turn On/Off Smart Stream mode. Smart Stream mode remarkably reduces the bandwidth and the data storage requirements for network cameras while ensuring the high quality of images, and it is a 10-level adjustable codec.</p> <p>Level: Level 1~10 are available as needed.</p>
Bit Rate Control	CBR: Constant Bitrate. The rate of CBR output is constant.
	VBR: Variable Bitrate. VBR files vary the amount of output data per time segment.
Image Quality	Low/Medium/High are available, this item is optional only if you select VBR.
Profile	The option is for H.264, Main/High/Base can be selected as needed.
I-frame Interval	Set the I-frame interval to 1~10. The number must be a multiple of the number of frames.

Image

Here you can configure image parameters to ensure the quality of captured images.

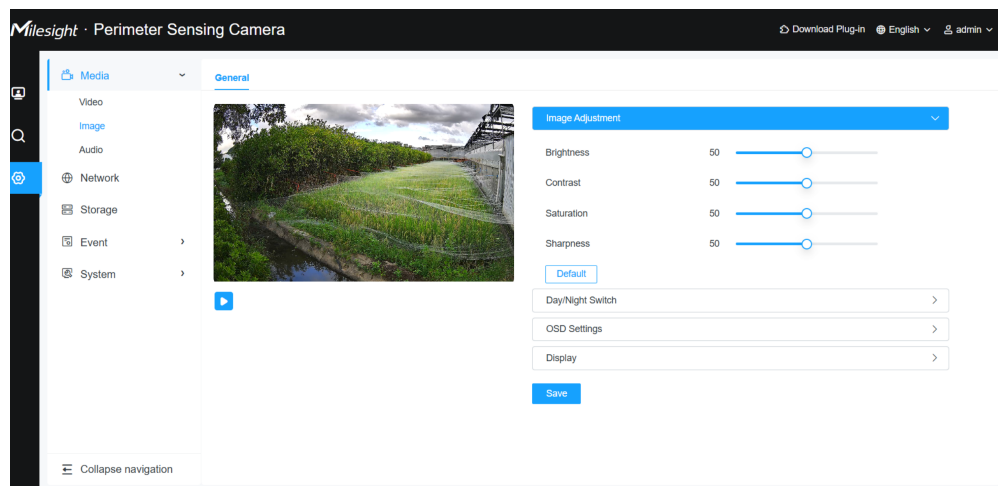

The configuration steps are as follows:

Step1: Configure Image Adjustment settings.

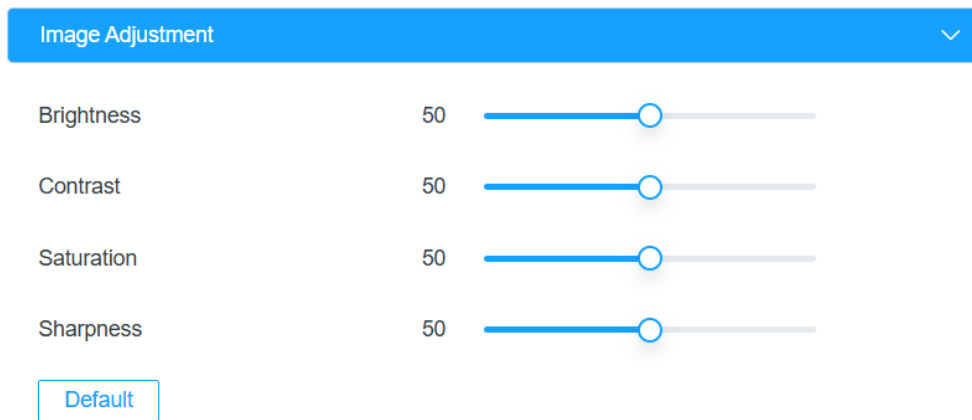
[Image Adjustment]**Table 5. Description of the buttons**

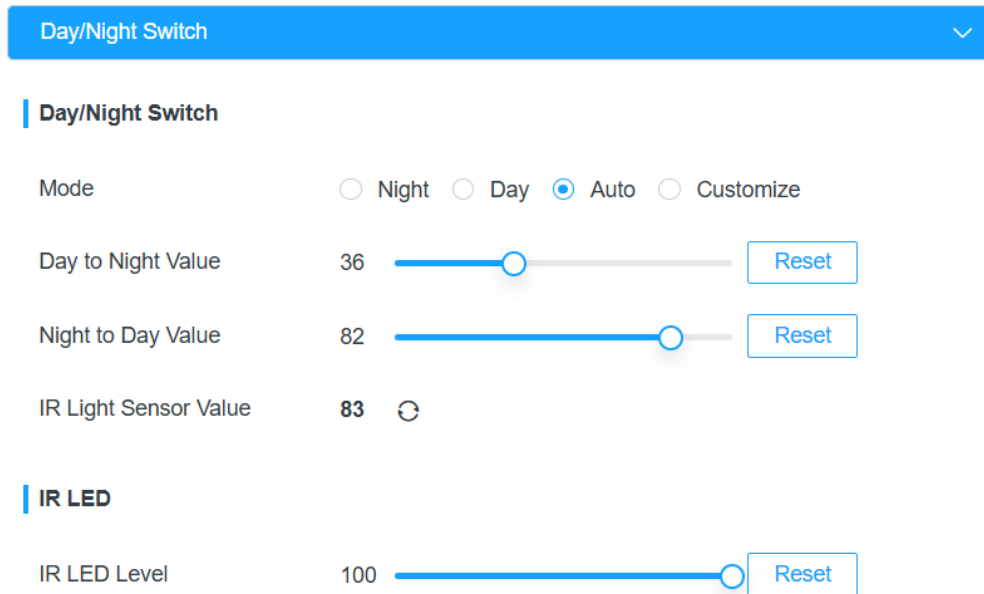

Parameters	Function Introduction
Brightness	Adjust the Brightness of the scene.
Contrast	Adjust the color and light contrast.
Saturation	Adjust the Saturation of the image. Higher Saturation makes colors appear more "pure" while lower one appears more "wash-out".
Sharpness	Adjust the Sharpness of image. Higher Sharpness sharpens the pixel boundary and makes the image looks "more clear".
Default	Click this button to restore to the default setting.

Step2: Configure Day/Night Switch settings.



Please refer to the meaning of the options as follows:

Table 6. Description of the buttons

Parameters	Function Introduction
Day/Night Mode	<p>Night Mode: Shown in live view based on Night Mode settings.</p> <p>Day Mode: Shown in live view based on Day Mode settings.</p> <p>Auto Mode: Shown in live view based on environment, set the sensitivity for switching Day Mode to Night Mode, or Night Mode to Day Mode.</p> <p>Customize: Select this option to customize the Start Time and End Time of Night.</p> <ul style="list-style-type: none"> • Start Time of Night: You can set the time to start the Night Mode. • End Time of Night: You can set the time to start the Day Mode.
Day/Night Switch	<p>Day to Night Value: You can set the sensitivity for switching Day Mode to Night Mode. When IR Light Sensor Current Value is lower than this value, it will switch Day Mode to Night Mode. You can click  to reset the value to 36.</p> <p>Night to Day Value: This is the sensitivity for switching Night Mode to Day Mode. When IR Light Sensor Current Value is higher than this value, it will switch Night Mode to Day Mode. You can click  to reset the value to 82.</p> <p>IR Light Sensor Value: The current value of the IR light sensor.</p> <p> Note: The three buttons are optional only if you select Auto Mode.</p>
IR LED Level	<p>You can also manually adjust the strength of the IR LED, the range is from 0 to 100. The default value is 100, click the Reset button to return to the default value.</p>

Step3: Configure OSD Settings.

OSD Settings
▼

OSD Settings

Show Timestamp

Show Device Name

Show Location Information

Show Background Color

Table 7. Description of the buttons

Parameters	Function Introduction
Show Timestamp	Click the checkbox to enable the display of timestamps.
Show Device Name	Click the checkbox to enable the display of device name.
Show Location Information	Click the checkbox to enable the display of real-time longitude and latitude coordinates.
Show Background Color	Click the checkbox to add a black background behind the OSD text for better contrast.

Step5: After completing the above settings, click  button to refresh the image.

[Display]

Display
▼

Power Line Frequency

60Hz

50Hz

Table 8. Description of the buttons

Parameters	Function Introduction
Power Line Frequency	60Hz and 50Hz are available.

Audio

Audio

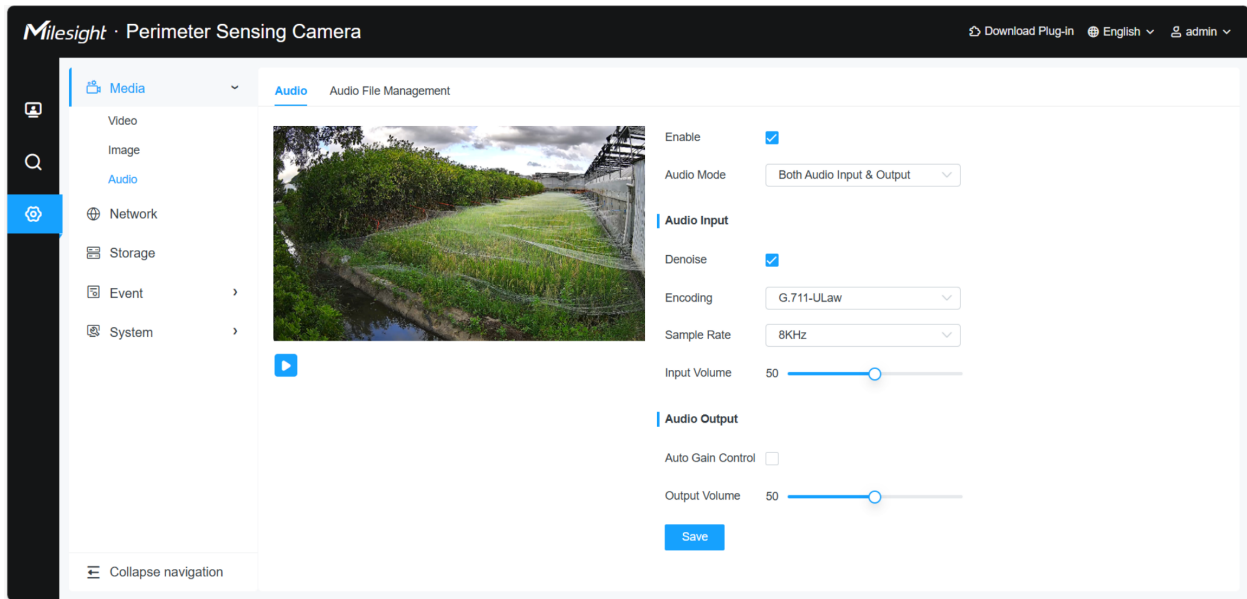
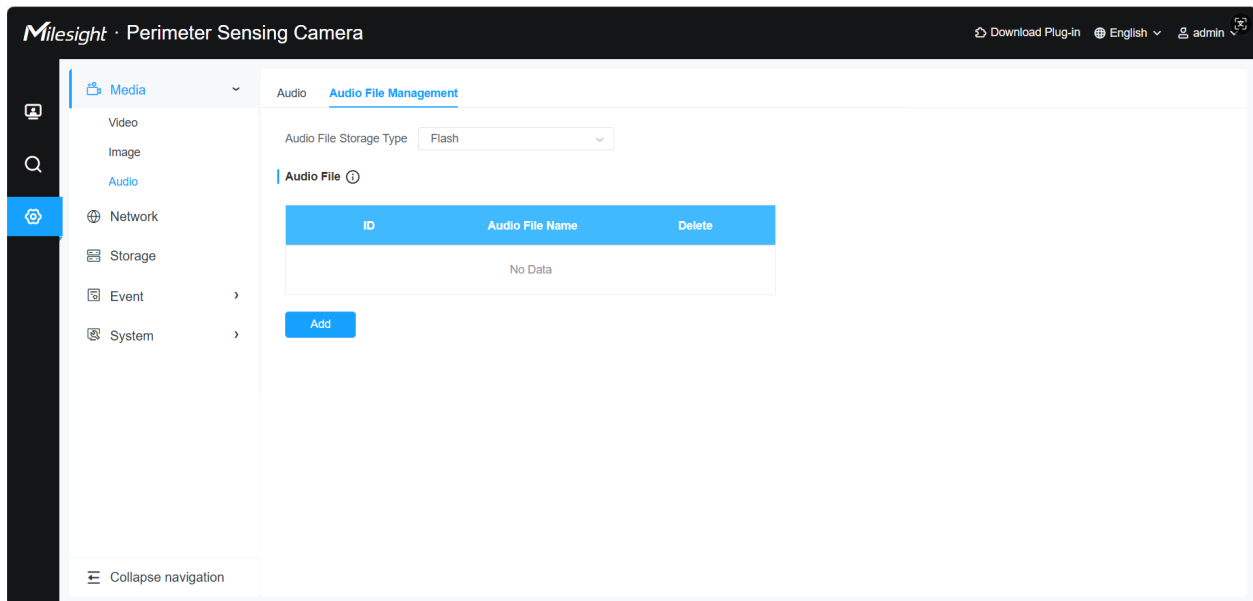

Table 9. Description of the buttons

Parameters	Function Introduction
Enable	Check on the checkbox to enable audio feature.
Audio Mode	Audio Input/Audio Output/Both Audio Input & Output are optional.
Audio Input	<p>Denoise: Set it as On/Off. When you set the function on, the noise detected can be filtered.</p> <p>Encoding: G.711-ULaw, G.711-ALaw, AAC LC, G.722 and G.726 are available</p> <p>Audio Bit Rate: The function is available only for AAC LC, and supports up to 48kbps.</p> <p>Sample Rate: 8KHz, 16KHz, 32KHz, 44.1KHz and 48KHz are available.</p> <p>Input Volume: Adjust volume of input.</p>
Audio Output	<p>Auto Gain Control: This function is only for H.265 series, improve the quality of audio.</p> <p>Output Volume: Adjust volume of output.</p>

Audio File Management

You can upload up to 5 audio files manually to SD Card on the Audio web page and you can also edit the audio file's name when upload.



Note: Only support '.wav' audio files with codec type PCM/PCMU/PCMA, 64kbps or 128 kbps and no more than 10M.

Chapter 6. Network

Cellular

You can check the cellular status and set the cellular settings here when using the camera, as shown below.

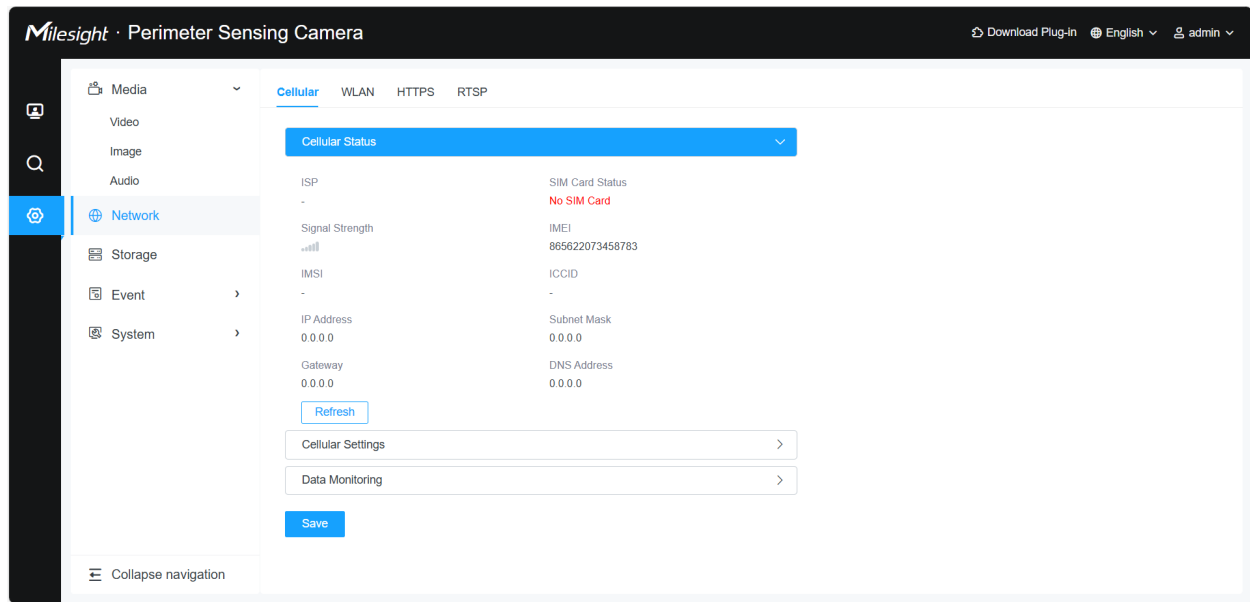

Note:

- Before using the 4G network, please insert the SIM card into the SIM card slot at the bottom of the camera. It supports Nano SIM for SIM card slot.

[Cellular Settings]

Step1: Fill in the information provided by your Internet Service Provider (ISP) to Cellular Settings interface, then click Save to access the network successfully.

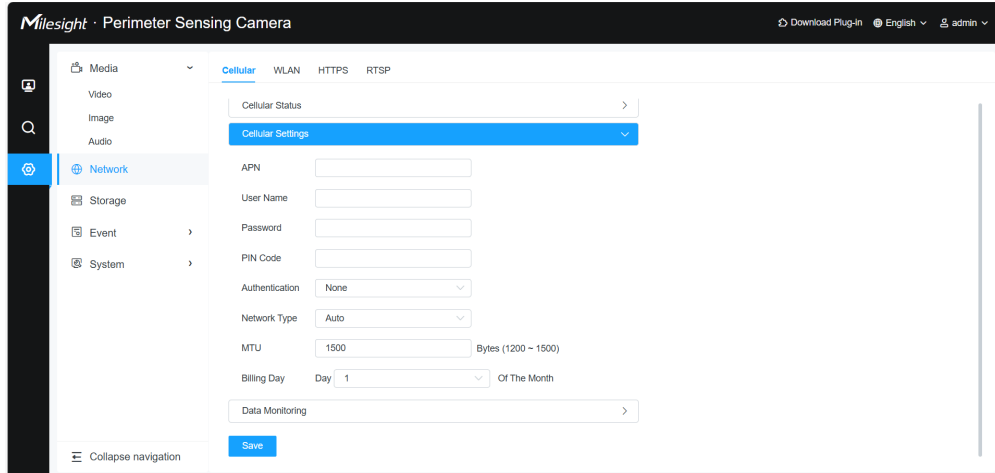

Table 10. Description of the buttons

Parameters	Function Introduction
APN	Enter the Access Point Name for cellular dial-up connection provided by local ISP.
User name	Enter the user name for cellular dial-up connection provided by local ISP.
Password	Enter the password for cellular dial-up connection provided by local ISP.
PIN Code	Enter a 4-8 characters PIN code to unlock the SIM.
Authentication	Select the Authentication Type. There are three options: None , PAP and CHAP , to match different Internet Service Providers. The default option is None .
Network Type	Select the network type of cellular network. There are three options including Auto, 4G Only and 3G Only. Auto: connect to the network with the strongest signal automatically.
MTU	Selectable 1200~1500 Bytes. MTU stands for Maximum Transmission Unit. It specifies the maximum size (in bytes) of each data packet that can be sent over the network.
Billing Day	Select the date for clearing the data each month. Users can choose from 1st to 31st, and the system will clear the data on the date you set each month.

[Cellular Status]

Step2: After connecting to the network successfully, you can check the cellular status information on Cellular Status interface, as shown below.

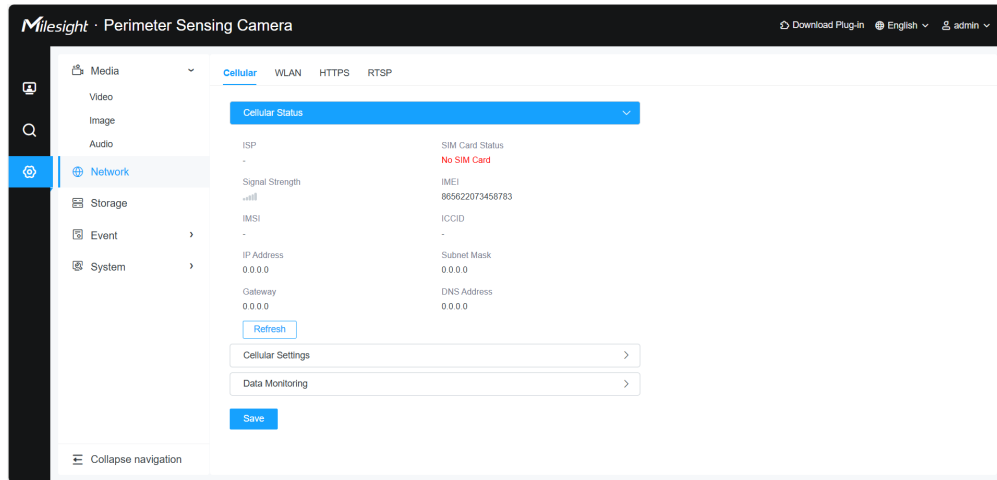

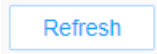

Table 11. Description of the buttons

Parameters	Function Introduction
ISP	Show the network provider which the SIM card registers on.  Note: It will display "-" when the SIM card is not inserted or not recognized.
SIM Card Status	Display the connection status of SIM card. No SIM Card: The SIM card is not inserted. SIM PIN Code Required: The SIM card is locked by a PIN code. SIM PUK Code Required: The SIM card is locked due to multiple incorrect PIN entries. The PUK code is required to unlock it. Invalid: The SIM card has been inserted but failed to connect to the network. Valid: The SIM card has been inserted and successfully connected to the network.
Signal Strength	Display the current signal strength of the network.
IMEI	Show the IMEI of the module.
IMSI	Show IMSI of the SIM card.
ICCID	Show ICCID of the SIM card.
IP Address	Display the IP Address, Subnet Mask, Gateway and DNS Address of the current network. If the SIM card is not inserted or not recognized, it will display 0.0.0.0.
Subnet Mask	
Gateway	
DNS Address	
	Click this button to manually refresh the above status.

[Data Monitoring]

Step 3: Effective data monitoring is crucial for managing the cellular data usage of your security camera. This section provides detailed information on how to monitor data usage and configure pre-alarm actions to optimize data consumption.

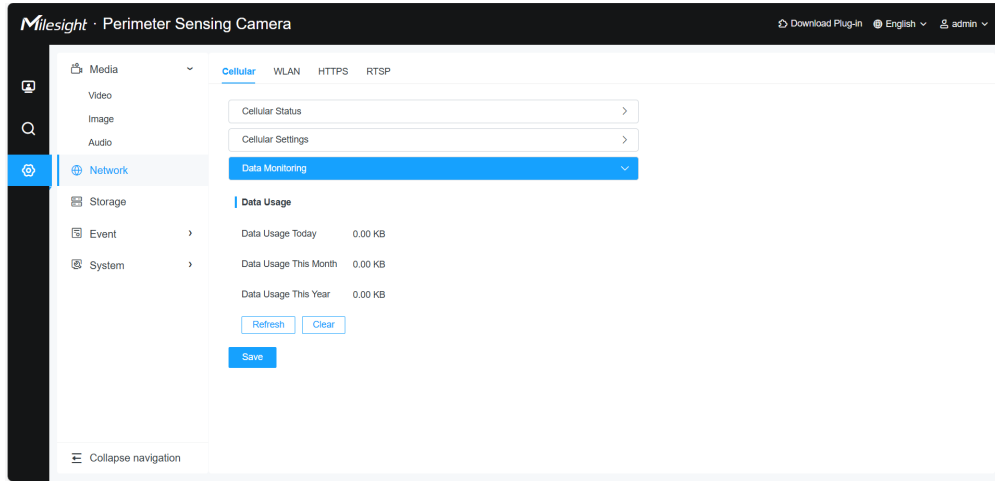

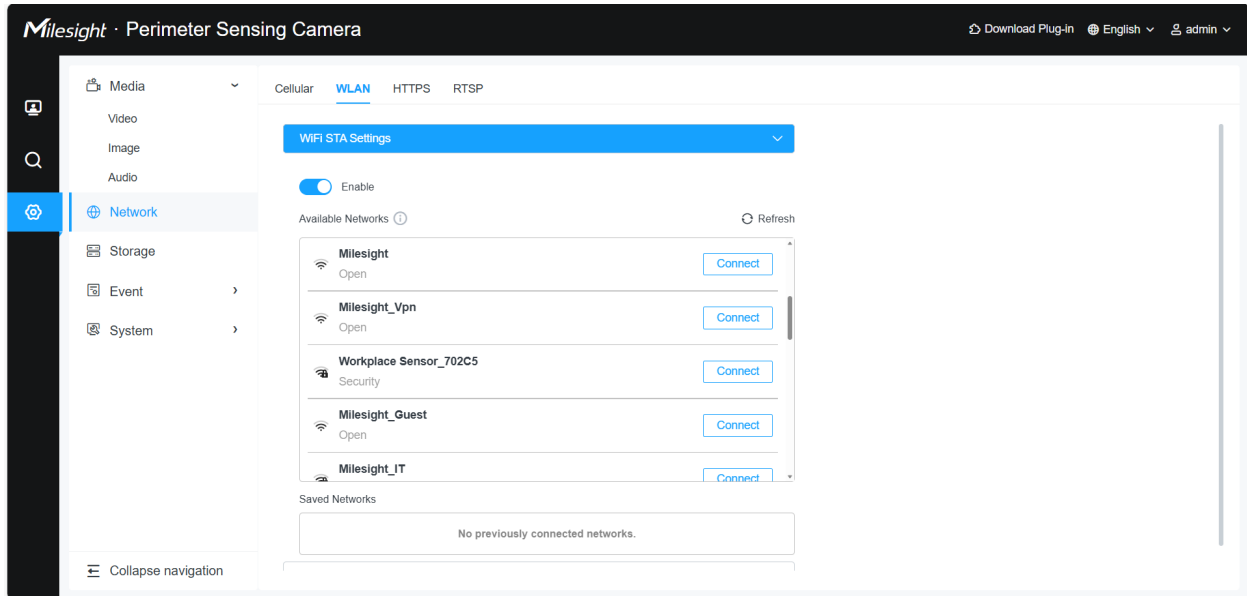

Table 12. Description of the buttons

Parameters	Function Introduction
Data Usage	Displays the total amount of cellular data used by the camera today/this month/this year. Refresh: Refresh Data. Clear: Clear all data usage, this action is irreversible.
	Click this button to manually refresh the above status.

WLAN

[Wi-Fi STA Settings]



Wi-Fi Station (STA) mode allows the camera to connect to an external Wi-Fi network for internet access and platform communication.

Enable Wi-Fi: Toggle this switch to turn the Wi-Fi client function on or off. **(Default: Enabled)**. When enabled, the camera will automatically scan for nearby signals.

Available Networks: This section lists all detectable Wi-Fi networks in the vicinity.

Table 13. Description of the buttons

Parameters	Function Introduction
SSID	Displays the names of available Wi-Fi networks.
Signal Strength	Represented by an icon showing the current reception quality.
Security Status	Indicates whether the network is encrypted (Padlock icon).
Connect	Click to initiate a connection to the selected network. A pop-up will appear requesting the Wi-Fi Password if the network is secured.

Connection Details (Status & Configuration)

Once the camera is successfully connected to a Wi-Fi network, the following information will be displayed for monitoring and advanced network configuration:

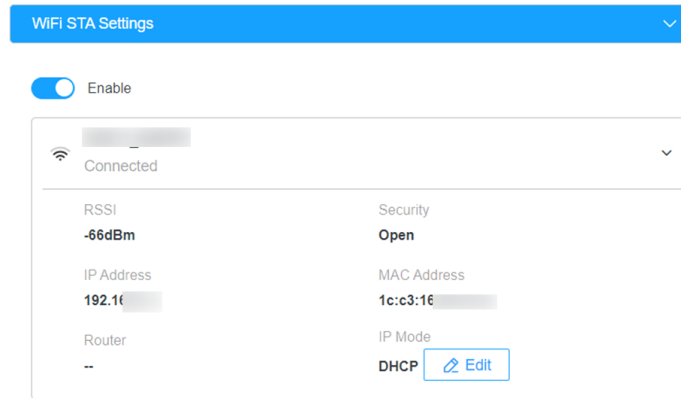

Table 14. Description of the buttons

Parameters	Function Introduction
RSSI	Displays the received signal strength indicator.
IP Address	The current IP assigned to the camera.
Router	The gateway or router index the device is connected to.
Security	Displays the encryption type of the current connection.
MAC Address	The unique hardware address of the Wi-Fi module.
IP Mode	<p>You can switch between these modes:</p> <ul style="list-style-type: none"> • DHCP: Automatically obtains an IP from the router. • Static: Allows you to manually assign a fixed IP address to the camera.

Saved Networks: This list displays networks that the camera has previously connected to or that have been manually added.

1. **Automatic Reconnection:** The camera will prioritize connecting to networks in this list if they are available.
2. **Management:** You can view the status of saved networks or click **[Delete]** to remove a network's credentials from the device memory.

[AP Settings]

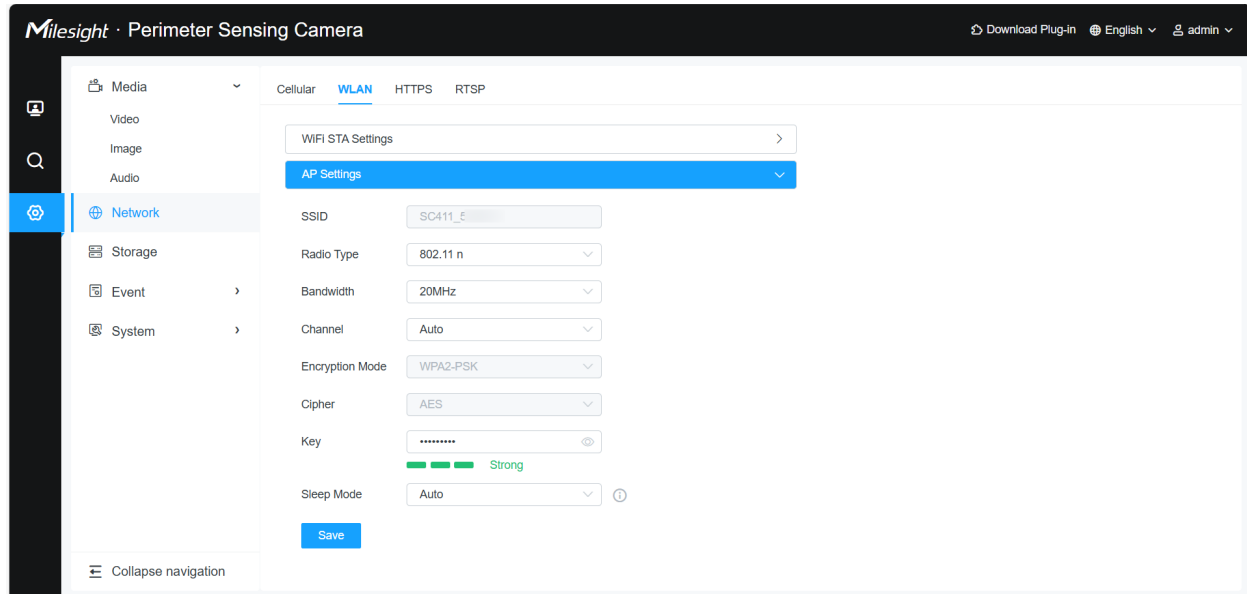



Table 15. Description of the buttons

Parameters	Function Introduction
SSID	Configure the wireless network name, default is SC411_XXXXXX (last six digits of the MAC address), not editable.
Radio Type	Select the radio type for Wi-Fi connection. Available options are 802.11n and 802.11g.
Bandwidth	Select the bandwidth for Wi-Fi connection. If Radio Type is set to 802.11n: 20MHz, 40MHz. If Radio Type is set to 802.11g: 20MHz.
Channel	Select the channel for Wi-Fi connection.
Encryption Mode	Fixed to WPA2-PSK (Required for GDPR compliance).
Cipher	Fixed to AES .
Key	8–63 characters. Must include uppercase, lowercase, numbers, and special characters. Must reach Strong status to save.
Sleep Mode	Configure the WiFi module to enter sleep mode, selectable options are Auto/Never.  Note: Recommend selecting the 'Auto' mode, where the Wi-Fi will enter sleep mode after five minutes of inactivity between the device and the external environment. Choosing 'Never' mode will result in higher device power consumption.
	Click this button to manually refresh the above status.

HTTPS

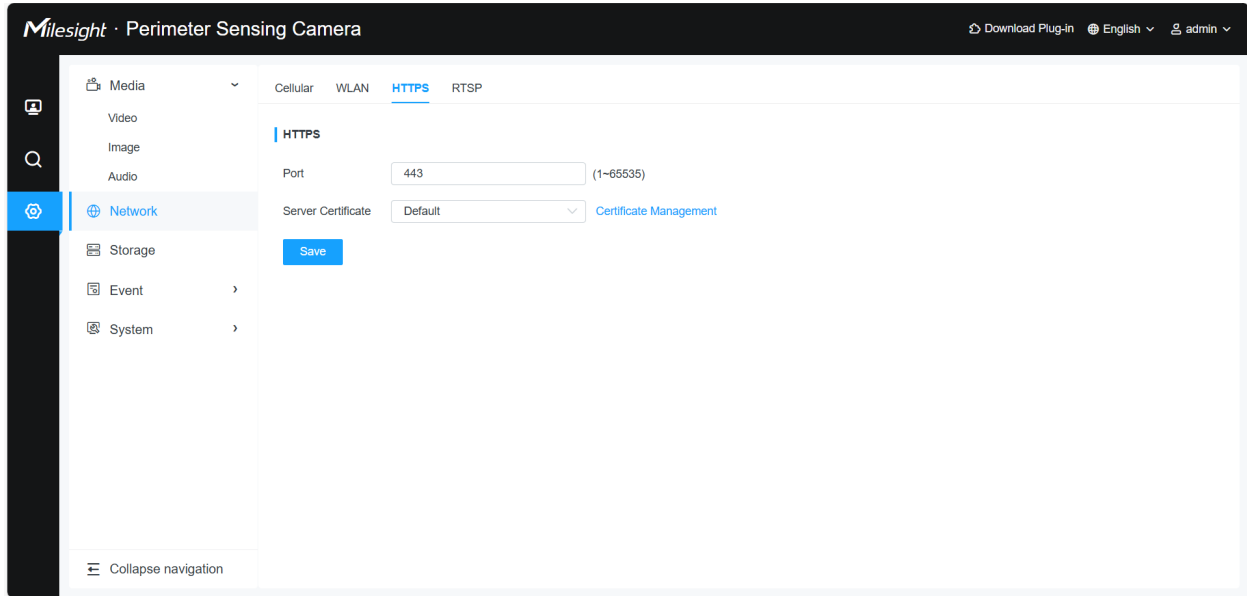



Table 16. Description of the buttons

Parameters	Function Introduction
HTTPS	<p>Port: Web GUI login port via HTTPS, the default is 443.</p> <p> Note: For more details about how to use enable HTTPS access, please refer to https://milesight.freshdesk.com/a/solutions/articles/69000797384.</p>
Certificate Management	Upload and set the SSL certificate.
Save	Save the configuration.

RTSP

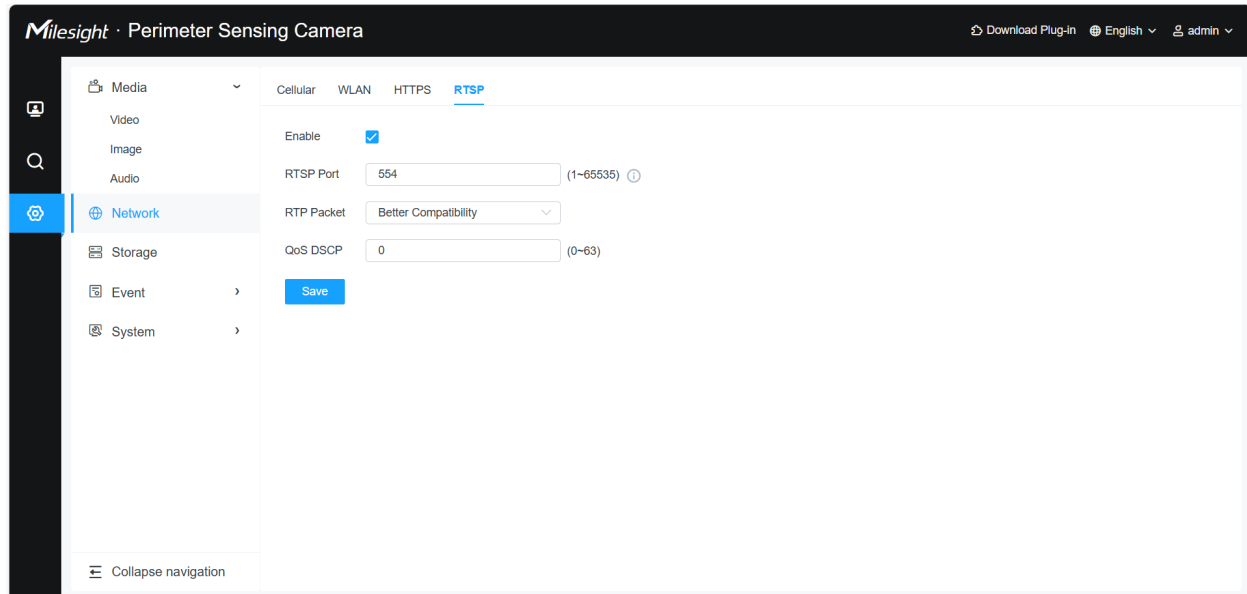

Table 17. Description of the buttons

Parameters	Function Introduction
RTSP Port	The port of RTSP, the default is 554.
RTP Packet	There are Better Compatibility and Better Performance two options, if your camera's image mess up, please switch this option.
QoS DSCP	The valid value range of the DSCP is 0-63.
	Save the configuration.

Table 18. RTSP URL are as below:

Stream	URL
Primary Stream	rtsp://IP:RTSP Port/main

 **Note:**

- DSCP refers to the Differentiated Service Code Point; and the DSCP value is used in the IP header to indicate the priority of the data.
- A reboot is required for the settings to take effect.

Chapter 7. Storage

Storage Management

In this section, you can manage the SD card status, storage logic, and data security settings to optimize the device's performance and comply with privacy regulations.

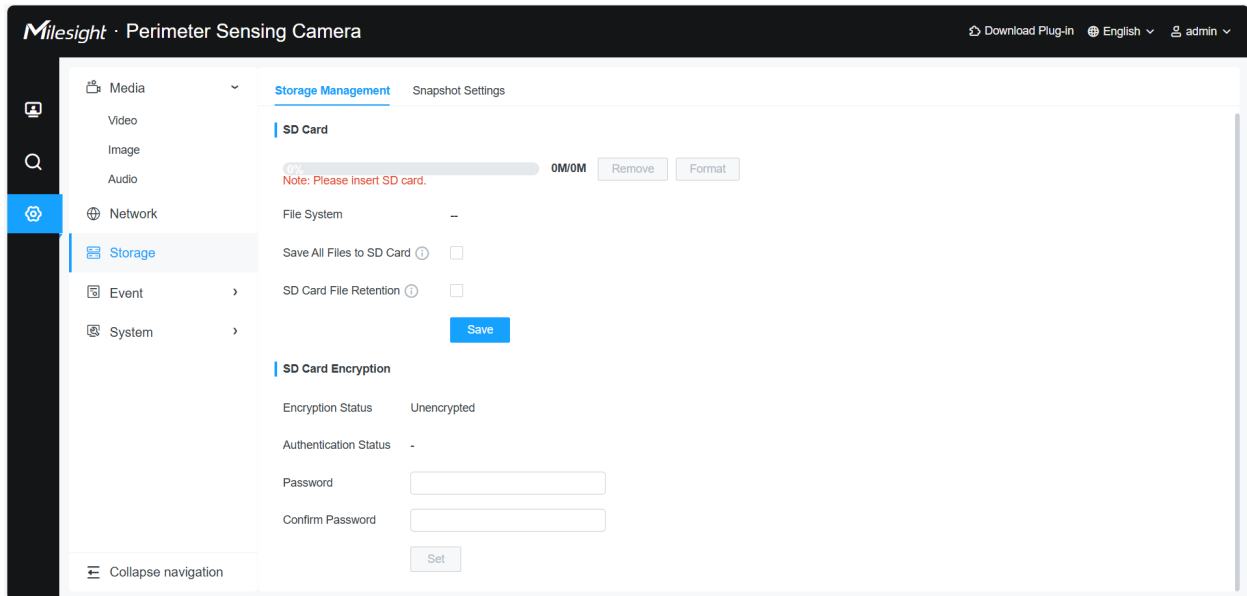

Note: Before you start:

- Before using the SD card for the first time, please format the card on the camera.
- To configure record settings, please make sure that you have the SD card inserted in your camera.

Please refer to the meaning of the options as follows:

Table 19.

Item	Description
SD Card	Format: Format the SD card, the files in the SD card will be removed. Remove: Remove SD card.
File System	Displays the file system format (e.g., EXT4). If no SD card is inserted, it displays "-".
Save All Files to SD Card	When disabled, event videos, event snapshots, and scheduled snapshots will not be stored on the SD card if they are successfully uploaded/pushed to the backend. This extends SD card lifespan and enhances data security.

Item	Description
SD Card File Retention	Enable this to set a specific storage period for recordings and snapshots. Once the retention period is reached, files will be automatically deleted. Retention Time: Set the number of days to keep files on the SD card. Range: 1~90 days (Default: 30).
<div style="background-color: #007bff; color: white; padding: 5px; display: inline-block;">Save</div>	Click to apply and save all configurations in the SD Card module.

[SD Card Encryption]

Provides advanced security mechanisms to protect stored data, ensuring compliance with **EU GDPR** privacy requirements.

Table 20.

Item	Description
Encryption Status	Displays whether the SD card file system is currently "Encrypted" or "Unencrypted".
Authentication Status	Shows the current password protection status.
Password / Confirm Password	Set or confirm the encryption password to secure the data on the SD card.

 **Note:** Once the SD card is encrypted, the encryption cannot be removed directly. If you need to clear the encryption and return the card to an unencrypted state, the **SD card must be formatted**, which will erase all existing data.

Snapshot Settings

Configure the image parameters for captured snapshots to balance image clarity and data transmission efficiency.

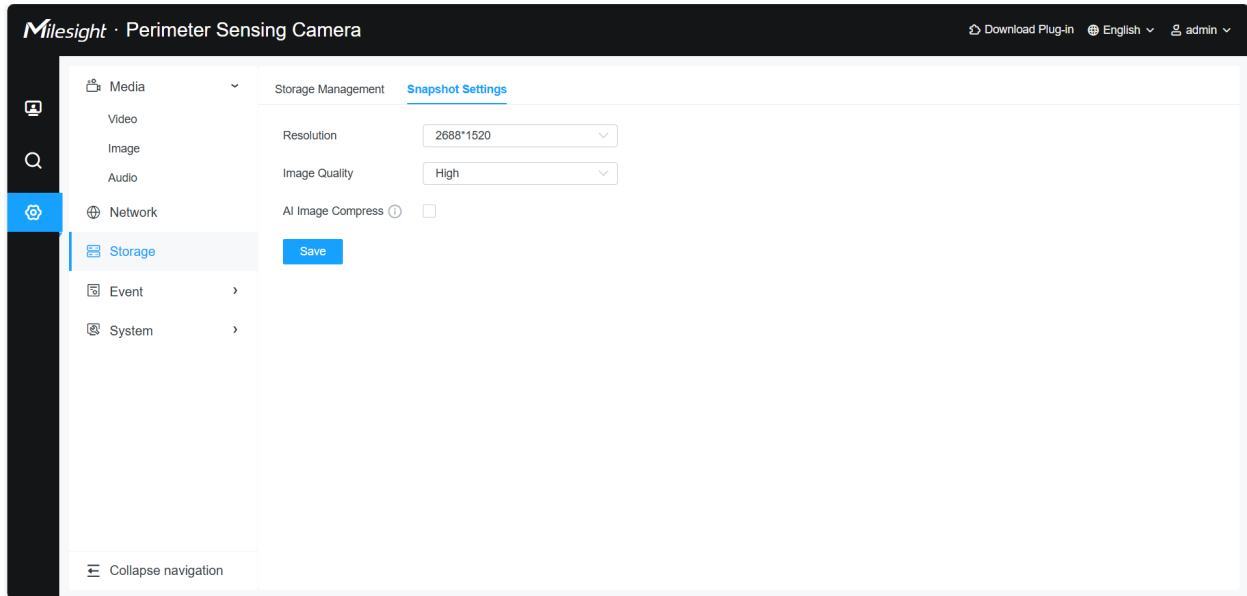

Table 21. Description of the buttons

Parameters	Function Introduction
Resolution	Select the resolution for snapshots. It synchronizes with the main stream options: 2688*1520 , 2304*1296 , 1920*1080 , or 1280*720 .
Image Quality	Adjust the overall compression level for the entire image file. Options include Low , Medium , and High . (Default: High)
AI Image Compress	Enable this to activate AI-based image processing. It focuses on maintaining target clarity (human/vehicle) while optimizing background data to reduce file size.
Save	Save the configuration.

Chapter 8. Event

Motion Detection

The Motion Detection module allows the camera to identify movement within specific areas. By combining PIR and AOV technologies, the camera balances ultra-low power consumption with high-accuracy event triggering.

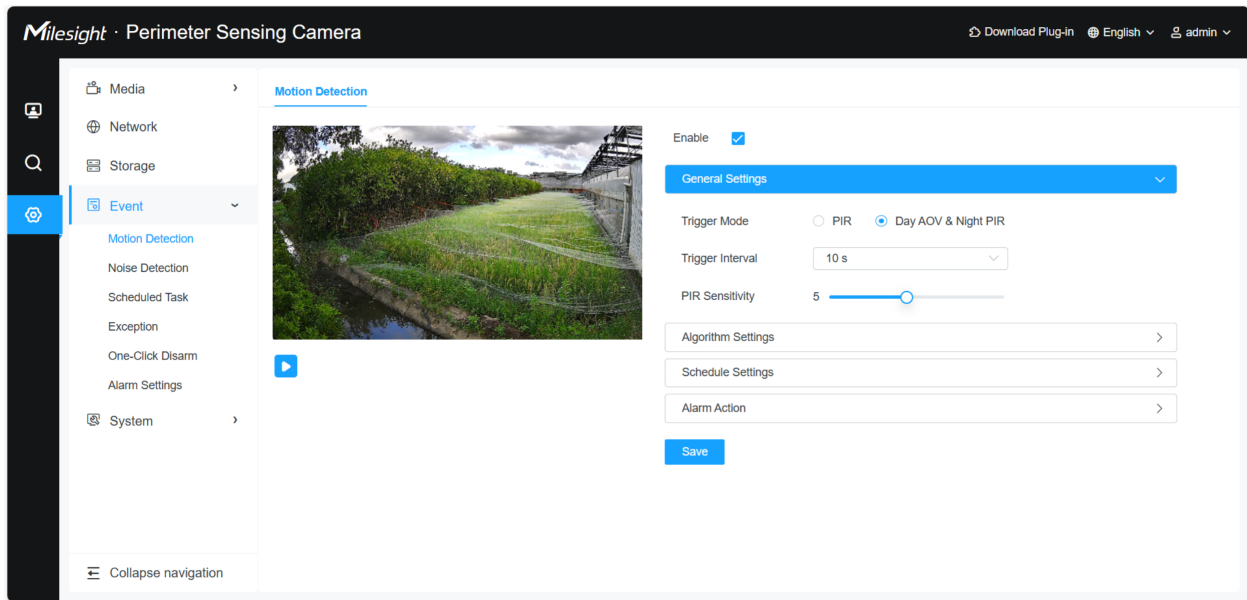

Settings steps are shown as follows:

Step1: Check the checkbox to enable the motion detection.

Table 22. Description of the buttons

Parameters	Function Introduction
Enable	Check the checkbox to enable Motion Detection function.

Step2: Select the trigger mode.

[General Settings]

General Settings
▼

Trigger Mode PIR Day AOV & Night PIR

Trigger Interval ▼

PIR Sensitivity 5

Table 23. Description of the buttons

Parameters	Function Introduction
Trigger Mode	<p>PIR: Uses the Passive Infrared sensor for detection (lowest power).</p> <p>Day AOV & Night PIR: Uses AI-powered Always-on Video during the day and PIR at night for optimized accuracy.</p> <p> Note: Switching modes requires a device reboot.</p>
Trigger Interval	<p>Set the minimum time between consecutive alarms (10s to 1h). This prevents excessive notifications from a single continuous event.</p> <p>To better understand how the system handles actions within a short interval (e.g., 10 seconds), consider the following scenario:</p> <p>If an event is triggered with a 10s interval and the system is configured to perform a 5s recording and a 5s event action (such as an audio alert or light flash):</p> <ol style="list-style-type: none"> 1. Immediate Action (0s - 5s): The camera starts recording for the first 5 seconds and simultaneously triggers the event action. 2. Follow-up Action (5s - 10s): Once the recording is complete, the remaining 5 seconds of the interval act as the "waiting/cool-down" period. 3. New Trigger (After 10s): Only after the full 10-second interval has elapsed can the system be triggered again to start a new recording and action cycle.
PIR Sensitivity	Adjust the sensitivity of the PIR sensor (Range: 1~10). Higher values increase detection distance and responsiveness.

[Algorithm Settings]

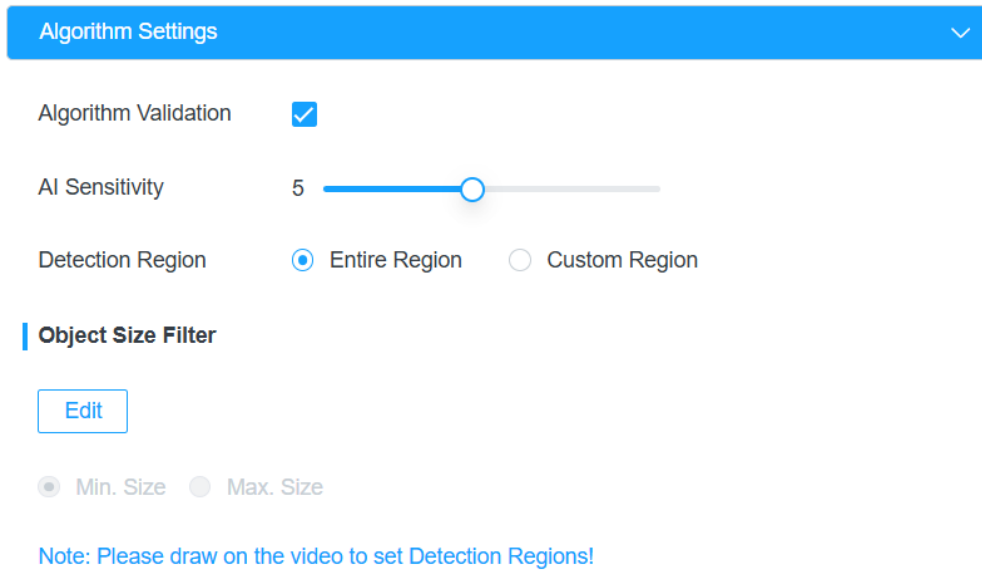

Table 24. Description of the buttons



Parameters	Function Introduction
Algorithm Validation	(Enabled by default) When enabled, AI secondary filtering is activated to verify targets (human/vehicle), significantly reducing false alarms.
AI Sensitivity	Adjust the sensitivity of the AI detection model (Range: 1~10).
Detection Region	<p>Entire Region: Monitors the full field of view.</p> <p>Custom Region: Allows users to draw up to 2 specific detection zones (up to 10-sided polygons) on the video preview.</p>
Object Size Filter	Define the minimum and maximum size of objects to be detected to filter out small animals or distant noise.

[Schedule Settings]

Step3: Set motion detection schedule;

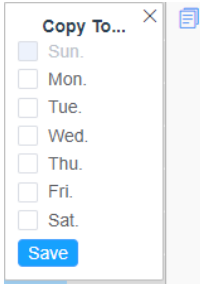

Table 25. Description of the buttons

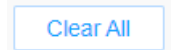
Parameters	Function Introduction
	<p>Copy the schedule area to another date.</p>
	<p>Select all schedule.</p>
	<p>Clear all schedule.</p>

[Alarm Action]

Step4: Set alarm action. Define what actions the camera takes once a motion event is confirmed.

Alarm Action
▼

Action Mode ▼
Snapshot Group

Capture Number ▼
1

Data Push

Enable

Alarm Server ▼
Select
[Alarm Server Management](#)

File Push Method ▼
General

Encoding Type Base64 Binary

Automatic Retransmission ⓘ (Please insert SD card.)

Data Edit

Code
Preview

Send Email

Enable (Please enable the Email.)

Play Audio





Enable

Audio File ▼
Default

Action Times ▼
1

Audio Action

Table 26. Description of the buttons

Parameters	Function Introduction
<p>Action Mode</p>	<p>Snapshot Group: Captures a sequence of 1~5 images. You can set the Capture Interval (300ms~1000ms) between shots.</p> <p>Video Clip: Records a short event video (2~5 seconds).</p> <p>Snapshot & Video Clip: Performs both actions for comprehensive evidence.</p>
<p>Data Push</p>	<p>The camera supports seamless data integration with backend servers (HTTP/HTTPS/MQTT).</p> <p>Alarm Server: Select the target server for data transmission.</p> <p> Note: This feature can only be enabled after the Alarm Server service is configured and tested in Event > Alarm Settings > Alarm Server.</p> <p>File Push Method: Supports General (standard server) or AWS S3 (direct cloud storage upload).</p> <p>Encoding Type: Choose between Base64 (text-based) or Binary (raw file) formats for data transmission.</p> <p>Automatic Retransmission:(Requires SD Card) If data push fails due to network issues, the camera will store the data on the SD card and attempt to resend it periodically once the connection is restored.</p> <p> Note: To successfully save captured images or videos to the SD card, you must enable the Data Push function and ensure that "Save All Files to SD Card" is enabled under the Storage settings menu. Without these configurations, files may only be transmitted to the server and not stored locally.</p> <div data-bbox="592 1094 1388 1402" style="border: 1px solid #ccc; padding: 5px; margin: 10px 0;"> <p style="text-align: right; font-size: 0.8em; color: #007bff;">Preview ✕</p> <div style="display: flex; justify-content: space-between;"> <div style="width: 48%;"> <p style="font-size: 0.8em; margin-bottom: 5px;">Code Pretty</p> <pre style="font-family: monospace; font-size: 0.8em; margin: 0;"> 1 { 2 "event_id": "\$event_id\$", 3 "event_type": "\$event_type\$", 4 "device_name": "\$device_name\$", 5 "mac_address": "\$mac_address\$", 6 "sn": "\$sn\$", 7 "latitude": "\$latitude\$", 8 "longitude": "\$longitude\$", 9 "altitude": "\$altitude\$", 10 "time": "\$time\$", 11 "time_msec": "\$time_msec\$", 12 "retransmit_time": "\$retransmit_time\$", 13 "retransmit_count": "\$retransmit_count\$", 14 "trigger_value": "\$trigger_value\$", 15 "snapshot": "\$snapshot_list\$" 16 } </pre> </div> <div style="width: 48%;"> <p style="font-size: 0.8em; margin-bottom: 5px;">Code</p> <pre style="font-family: monospace; font-size: 0.8em; margin: 0;"> 1 { 2 "event_id": "1776468755297", 3 "event_type": "Noise Detection", 4 "device_name": "Perimeter Sensing Camera", 5 "mac_address": "1C:C3:16:54:3F:6E", 6 "sn": "", 7 "latitude": "", 8 "longitude": "", 9 "altitude": "", 10 "time": "2026-04-17 16:32:35", 11 "time_msec": "2026-04-17 16:32:35.297", 12 "retransmit_time": "", 13 "retransmit_count": 0, 14 "trigger_value": 60, 15 "snapshot": [16 { 17 "index": 0, </pre> </div> </div> </div> <p>Data Editor: Allows users to view and customize the data fields pushed to the server in real-time.</p> <p> Note: The data content shown in the editor is a template/example; actual pushed data will vary based on the specific event type.</p>
<p>Send Email</p>	<p>Automatically sends event alerts with attachments to the configured email address.</p> <p> Note: This feature can only be enabled after the Email service is configured and tested in Event > Alarm Settings > Email.</p>

Parameters	Function Introduction
Play Audio	<p>Triggers a pre-recorded audio warning via the external speaker (requires Audio Speaker to be enabled in Media settings).</p> <p>Audio File:Select the specific audio file to be played from the dropdown list of uploaded files.</p> <p>Action Times:Specify how many times the audio file should repeat for a single alarm event.</p> <p>Audio Action:Define the trigger logic for the audio play. For each confirmed alarm, the camera will execute the set audio file and repetition count based on the configured schedule.</p>

Noise Detection

The Noise Detection module enables the camera to trigger alarms when the ambient sound level exceeds a predefined threshold. This is particularly useful for detecting unauthorized activities in quiet environments.

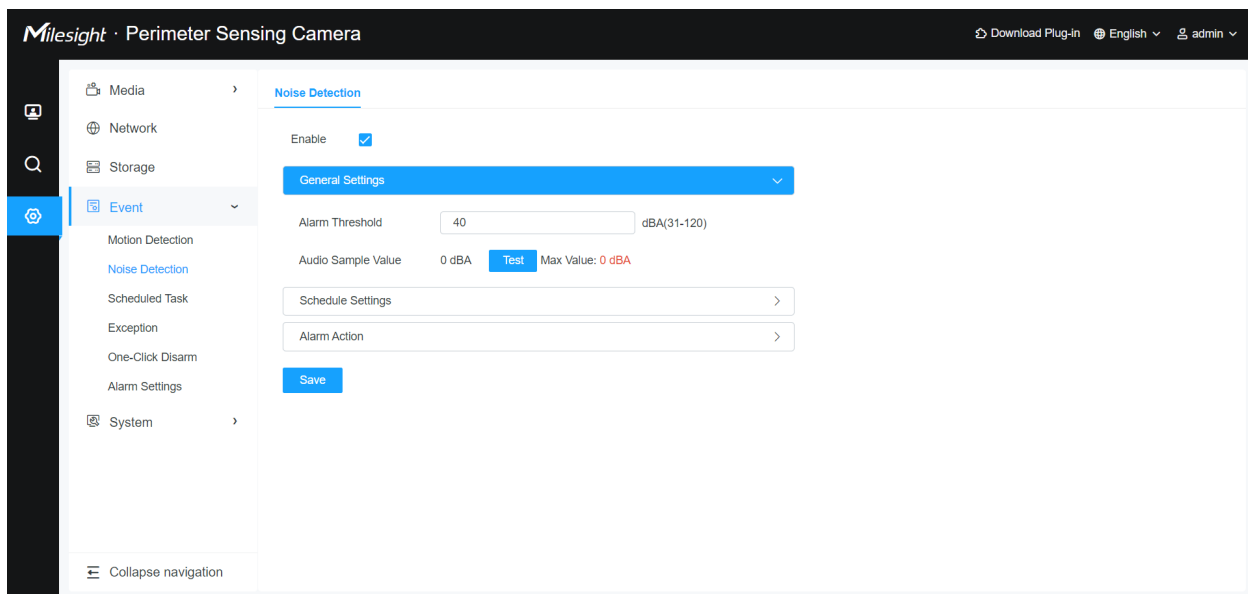

Settings steps are shown as follows:

Step1: Check the checkbox to enable the noise detection.

Table 27. Description of the buttons

Parameters	Function Introduction
Enable	Check the checkbox to enable Noise Detection function.

[General Settings]

General Settings
▼

Alarm Threshold dBA(31-120)

Audio Sample Value 0 dBA Test Max Value: 0 dBA

Table 28. Description of the buttons

Parameters	Function Introduction
Alarm Threshold	Set the decibel level (31~120 dBA) that will trigger an alarm. When the detected sound exceeds this value, the configured alarm actions will execute. (Default: 60 dBA).
Audio Sample Value	Displays the real-time ambient decibel level to ensure the microphone is working correctly.
Noise Level Test	Click [Test] to start real-time monitoring of sound levels. Click [End] to stop; the Max Value will display the highest decibel level recorded during the test period.

[Schedule Settings]

Step2: Set noise detection schedule;

Schedule Settings
▼

0

2

4

6

8

10

12

14

16

18

20

22

24

Sun.	
Mon.	
Tue.	
Wed.	
Thu.	
Fri.	
Sat.	

Select All
Clear All

Table 29. Description of the buttons

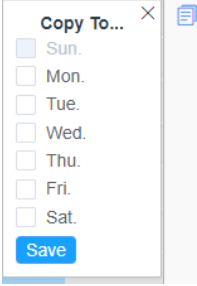
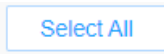
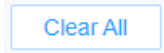
Parameters	Function Introduction
	<p>Copy the schedule area to another date.</p>
	<p>Select all schedule.</p>
	<p>Clear all schedule.</p>

[Alarm Action]

Step3: Set alarm action. Define what actions the camera takes once a motion event is confirmed.

Alarm Action
▼

Action Mode Snapshot Group ▼

Capture Number 1 ▼

Data Push

Enable

Alarm Server Select ▼
[Alarm Server Management](#)

File Push Method General ▼

Encoding Type Base64 Binary

Automatic Retransmission ⓘ (Please insert SD card.)

Data Edit

Code
Preview

Send Email

Enable (Please enable the Email.)

Play Audio

Enable





Audio File

Action Times

Audio Action 

Table 30. Description of the buttons

Parameters	Function Introduction
Action Mode	<p>Snapshot Group: Captures a sequence of 1~5 images. You can set the Capture Interval (300ms~1000ms) between shots.</p> <p>Video Clip: Records a short event video (2~5 seconds).</p> <p>Snapshot & Video Clip: Performs both actions for comprehensive evidence.</p>

Parameters	Function Introduction
<p style="text-align: center;">Data Push</p>	<p>The camera supports seamless data integration with backend servers (HTTP/HTTPS/MQTT).</p> <p>Alarm Server: Select the target server for data transmission.</p> <p> Note: This feature can only be enabled after the Alarm Server service is configured and tested in Event > Alarm Settings > Alarm Server.</p> <p>File Push Method: Supports General (standard server) or AWS S3 (direct cloud storage upload).</p> <p>Encoding Type: Choose between Base64 (text-based) or Binary (raw file) formats for data transmission.</p> <p>Automatic Retransmission:(Requires SD Card) If data push fails due to network issues, the camera will store the data on the SD card and attempt to resend it periodically once the connection is restored.</p> <p> Note: To successfully save captured images or videos to the SD card, you must enable the Data Push function and ensure that "Save All Files to SD Card" is enabled under the Storage settings menu. Without these configurations, files may only be transmitted to the server and not stored locally.</p> <div data-bbox="591 877 1386 1188" style="border: 1px solid #ccc; padding: 10px; margin: 10px 0;"> <p style="text-align: right; font-size: small; color: #007bff;">Preview ✕</p> <div style="display: flex; justify-content: space-between;"> <div style="width: 48%;"> <p style="font-size: x-small; margin: 0;">Code Pretty</p> <pre style="font-family: monospace; font-size: x-small; margin: 0;"> 1 (2 "event_id": "event_id", 3 "event_type": "event_type", 4 "device_name": "device_name", 5 "mac_address": "mac_address", 6 "snr": "snr", 7 "latitude": "latitude", 8 "longitude": "longitude", 9 "altitude": "altitude", 10 "time": "time", 11 "time_msec": "time_msec", 12 "retransmit_time": "retransmit_time", 13 "retransmit_count": "retransmit_count", 14 "trigger_value": "trigger_value", 15 "snapshot": "snapshot_list" 16) </pre> </div> <div style="width: 48%;"> <p style="font-size: x-small; margin: 0;">Code</p> <pre style="font-family: monospace; font-size: x-small; margin: 0;"> 1 (2 "event_id": "1776468755297", 3 "event_type": "Noise Detector", 4 "device_name": "Perimeter Sensing Camera", 5 "mac_address": "1C:03:16:54:3F:8E", 6 "snr": "", 7 "latitude": "", 8 "longitude": "", 9 "altitude": "", 10 "time": "2026-04-17 16:32:35", 11 "time_msec": "2026-04-17 16:32:35.297", 12 "retransmit_time": "-", 13 "retransmit_count": 0, 14 "trigger_value": 60, 15 "snapshot": [16 (17 "index": 0, </pre> </div> </div> </div> <p>Data Editor: Allows users to view and customize the data fields pushed to the server in real-time.</p> <p> Note: The data content shown in the editor is a template/example; actual pushed data will vary based on the specific event type.</p>
<p style="text-align: center;">Send Email</p>	<p>Automatically sends event alerts with attachments to the configured email address.</p> <p> Note: This feature can only be enabled after the Email service is configured and tested in Event > Alarm Settings > Email.</p>
<p style="text-align: center;">Play Audio</p>	<p>Triggers a pre-recorded audio warning via the external speaker (requires Audio Speaker to be enabled in Media settings).</p> <p>Audio File:Select the specific audio file to be played from the dropdown list of uploaded files.</p> <p>Action Times:Specify how many times the audio file should repeat for a single alarm event.</p> <p>Audio Action:Define the trigger logic for the audio play. For each confirmed alarm, the camera will execute the set audio file and repetition count based on the configured schedule.</p>

Scheduled Task

The Scheduled Task feature allows the camera to capture snapshots at specific intervals according to a predefined schedule. This is ideal for environmental monitoring, site progress tracking, or routine security checks.

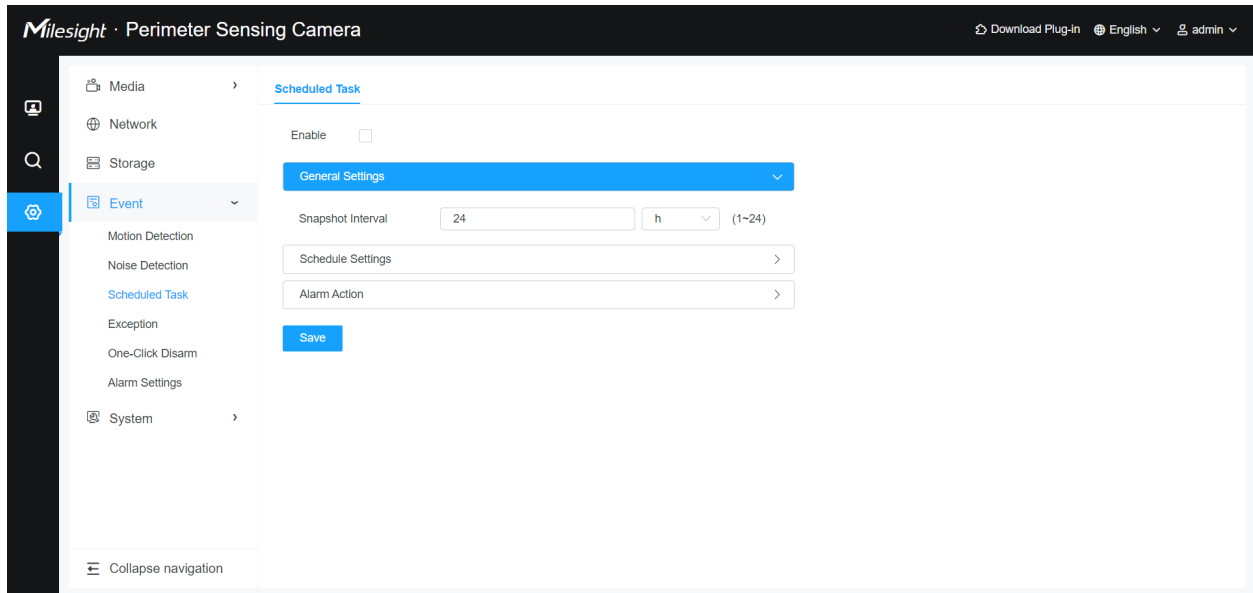

Settings steps are shown as follows:

Step1: Check the checkbox to enable the scheduled task.

Table 31. Description of the buttons

Parameters	Function Introduction
Enable	Check the checkbox to enable Scheduled Task function.

[General Settings]

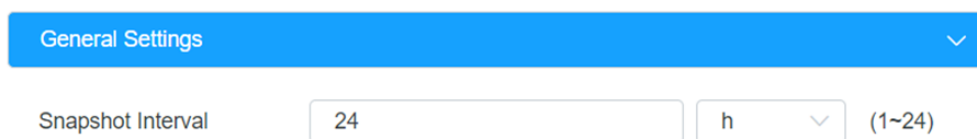

Table 32. Description of the buttons

Parameters	Function Introduction
Snapshot Interval	Define the time frequency between each snapshot. The system will trigger the first capture at the start of each active schedule period.

[Schedule Settings]

Step2: Set scheduled task schedule;

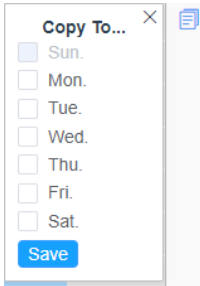
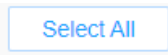
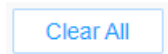

Table 33. Description of the buttons

Parameters	Function Introduction
	Copy the schedule area to another date.
	Select all schedule.
	Clear all schedule.

[Alarm Action]

Step3: Set alarm action. Define what actions the camera takes once a motion event is confirmed.

Alarm Action
▼

Data Push

Enable

Upload Mode ⓘ Immediacy Timing (Please insert SD card.)

Alarm Server ▼
Alarm Server Management

File Push Method ▼

Encoding Type Base64 Binary

Automatic Retransmission ⓘ (Please insert SD card.)

Data Edit

Code
Preview



```

1  {
2      "event_id": "$event_id$",
3      "event_type": "$event_type$",
4      "device_name": "$device_name$",
5      "mac_address": "$mac_address$",
6      "sn": "$sn$",
7      "latitude": "$latitude$",
8      "longitude": "$longitude$",
9      "altitude": "$altitude$",
10     "time": "$time$",
11     "time_msec": "$time_msec$",
12     "retransmit_time": "$retransmit_time$",
13     "retransmit_count": "#retransmit_count#",
14     "snapshot": "[snapshot_list]"
15 }
```

Send Email

Enable (Please enable the Email.)

Table 34. Description of the buttons

Parameters	Function Introduction
	<p>Immediacy: Snapshots are uploaded to the server immediately after being captured.</p> <p>Timing: Snapshots are saved to the SD card first and uploaded in batches at specific times of the day to save power or bandwidth. <i>(Requires an SD card).</i></p> <p>Frequency & Time (Timing Mode only):</p> <ul style="list-style-type: none"> • Once a day: Select one specific time (Time 1) for batch uploading. • Twice a day: Select two specific times (Time 1 & Time 2) for batch uploading.
<p>Data Push</p>	<p>The camera supports seamless data integration with backend servers (HTTP/HTTPS/ MQTT).</p> <p>Alarm Server: Select the target server for data transmission.</p> <p> Note: This feature can only be enabled after the Alarm Server service is configured and tested in Event > Alarm Settings > Alarm Server.</p> <p>File Push Method: Supports General (standard server) or AWS S3 (direct cloud storage upload).</p> <p>Encoding Type: Choose between Base64 (text-based) or Binary (raw file) formats for data transmission.</p> <p>Automatic Retransmission:(Requires SD Card) If data push fails due to network issues, the camera will store the data on the SD card and attempt to resend it periodically once the connection is restored.</p> <p> Note: To successfully save captured images or videos to the SD card, you must enable the Data Push function and ensure that "Save All Files to SD Card" is enabled under the Storage settings menu. Without these configurations, files may only be transmitted to the server and not stored locally.</p> <div data-bbox="548 1354 1347 1663" style="border: 1px solid #ccc; padding: 10px; margin: 10px 0;"> <p style="text-align: right; font-size: small;">Preview ✕</p> <div style="display: flex; justify-content: space-between;"> <div style="width: 48%;"> <p style="font-size: x-small; margin: 0;">Code Pretty</p> <pre style="font-family: monospace; font-size: x-small; margin: 0;"> 1 { 2 "event_id": "\$event_id\$", 3 "event_type": "\$event_type\$", 4 "device_name": "\$device_name\$", 5 "mac_address": "\$mac_address\$", 6 "sn": "\$sn\$", 7 "latitude": "\$latitude\$", 8 "longitude": "\$longitude\$", 9 "altitude": "\$altitude\$", 10 "time": "\$time\$", 11 "time_msec": "\$time_msec\$", 12 "retransmit_time": "\$retransmit_time\$", 13 "retransmit_count": "\$retransmit_count\$", 14 "trigger_value": "\$trigger_value\$", 15 "snapshot": "\$snapshot_list\$" 16 }</pre> </div> <div style="width: 48%;"> <p style="font-size: x-small; margin: 0;">Code</p> <pre style="font-family: monospace; font-size: x-small; margin: 0;"> 1 { 2 "event_id": 1776468755297, 3 "event_type": "Noise Detection", 4 "device_name": "Perimeter Sensing Camera", 5 "mac_address": "1C-C3-16-54-3F-6E", 6 "sn": "", 7 "latitude": "", 8 "longitude": "", 9 "altitude": "", 10 "time": "2026-04-17 16:32:35", 11 "time_msec": "2026-04-17 16:32:35.297", 12 "retransmit_time": "", 13 "retransmit_count": 0, 14 "trigger_value": 60, 15 "snapshot": [16 { 17 "index": 0,</pre> </div> </div> </div> <p>Data Editor: Allows users to view and customize the data fields pushed to the server in real-time.</p> <p> Note: The data content shown in the editor is a template/example; actual pushed data will vary based on the specific event type.</p>

Parameters	Function Introduction
Send Email	Automatically sends event alerts with attachments to the configured email address.  Note: This feature can only be enabled after the Email service is configured and tested in Event > Alarm Settings > Email .

Exception

Tamper Detection

This feature uses integrated **ToF sensors** and **Gyroscopes** to detect if the camera is being obstructed or physically manipulated.

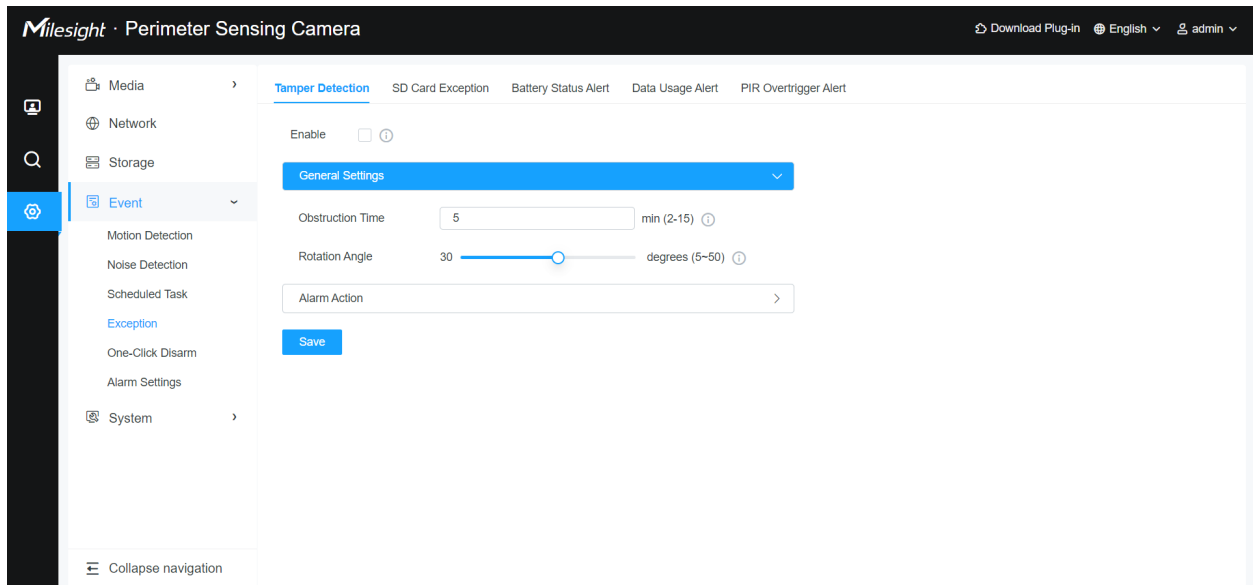

Settings steps are shown as follows:

Step1: Check the checkbox to enable the tamper detection.

Table 35. Description of the buttons

Parameters	Function Introduction
Enable	Check the checkbox to enable Tamper Detection function.

[General Settings]

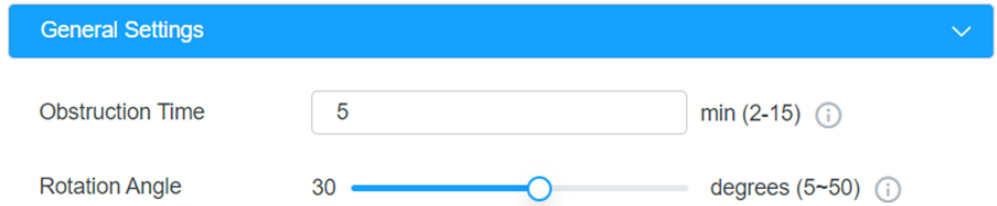

Table 36. Description of the buttons

Parameters	Function Introduction
Obstruction Time	An alarm is triggered only when the obstruction persists beyond this set time (2-15 min). This prevents false alarms from temporary obstructions (e.g., a bird flying by). <i>(Default: 5 min)</i>
Rotation Angle	Set the maximum allowed deviation in degrees (5° to 50°). An alarm is triggered immediately once the camera's pan, tilt, or roll angle exceeds this preset value relative to its initial position. (Default: 30°)

[Schedule Settings]

Step2: Set tamper detection schedule;

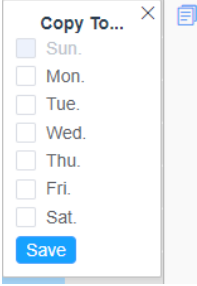
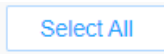
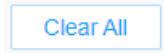

Table 37. Description of the buttons

Parameters	Function Introduction
	Copy the schedule area to another date.
	Select all schedule.
	Clear all schedule.

[Alarm Action]

Step3: Set alarm action. Define what actions the camera takes once a motion event is confirmed.

Alarm Action
▼

Data Push

Enable

Alarm Server ▼
[Alarm Server Management](#)

Automatic Retransmission ⓘ (Please insert SD card.)

Data Edit

Code
Preview

```

1  {
2    "event_id": "$event_id$",
3    "event_type": "$event_type$",
4    "device_name": "$device_name$",
5    "mac_address": "$mac_address$",
6    "sn": "$sn$",
7    "latitude": "$latitude$",
```

```
10  "time": "$time$",  
11  "time_msec": "$time_msec$",  
12  "retransmit_time": "$retransmit_time$",  
13  "retransmit_count": "#retransmit_count#"  
14  }
```

Send Email

Enable (Please enable the Email.)

Play Audio





Enable

Audio File

Action Times

Audio Action 

Table 38. Description of the buttons

Parameters	Function Introduction
<p style="text-align: center;">Data Push</p>	<p>The camera supports seamless data integration with backend servers (HTTP/HTTPS/MQTT).</p> <p>Alarm Server: Select the target server for data transmission.</p> <p> Note: This feature can only be enabled after the Alarm Server service is configured and tested in Event > Alarm Settings > Alarm Server.</p> <p>Automatic Retransmission:(Requires SD Card) If data push fails due to network issues, the camera will store the data on the SD card and attempt to resend it periodically once the connection is restored.</p> <p> Note: To successfully save captured images or videos to the SD card, you must enable the Data Push function and ensure that "Save All Files to SD Card" is enabled under the Storage settings menu. Without these configurations, files may only be transmitted to the server and not stored locally.</p> <div data-bbox="591 722 1386 1031" style="border: 1px solid #ccc; padding: 5px; margin: 10px 0;"> <div style="background-color: #007bff; color: white; text-align: center; padding: 2px;">Preview ✕</div> <div style="display: flex; justify-content: space-between;"> <div style="width: 48%;"> <p style="text-align: right; margin-bottom: 5px;">Code Pretty</p> <pre style="font-family: monospace; font-size: 0.9em;"> 1 { 2 "event_id": "\$event_id\$", 3 "event_type": "\$event_type\$", 4 "device_name": "\$device_name\$", 5 "mac_address": "\$mac_address\$", 6 "sn": "\$sn\$", 7 "latitude": "\$latitude\$", 8 "longitude": "\$longitude\$", 9 "altitude": "\$altitude\$", 10 "time": "\$time\$", 11 "time_msec": "\$time_msec\$", 12 "retransmit_time": "\$retransmit_time\$", 13 "retransmit_count": "\$retransmit_count\$", 14 "trigger_value": "\$trigger_value\$", 15 "snapshot": "\$snapshot_list" 16 }</pre> </div> <div style="width: 48%;"> <p style="text-align: right; margin-bottom: 5px;">Code</p> <pre style="font-family: monospace; font-size: 0.9em;"> 1 { 2 "event_id": 1776468755297, 3 "event_type": "Noise Detection", 4 "device_name": "Perimeter Sensing Camera", 5 "mac_address": "11C-C3:16:54:3F:5E", 6 "sn": "", 7 "latitude": "", 8 "longitude": "", 9 "altitude": "", 10 "time": "2026-04-17 16:32:35", 11 "time_msec": "2026-04-17 16:32:35.297", 12 "retransmit_time": "-", 13 "retransmit_count": 0, 14 "trigger_value": 60, 15 "snapshot": [16 { 17 "index": 0,</pre> </div> </div> </div> <p>Data Editor: Allows users to view and customize the data fields pushed to the server in real-time.</p> <p> Note: The data content shown in the editor is a template/example; actual pushed data will vary based on the specific event type.</p>
<p style="text-align: center;">Send Email</p>	<p>Automatically sends event alerts with attachments to the configured email address.</p> <p> Note: This feature can only be enabled after the Email service is configured and tested in Event > Alarm Settings > Email.</p>
<p style="text-align: center;">Play Audio</p>	<p>Triggers a pre-recorded audio warning via the external speaker (requires Audio Speaker to be enabled in Media settings).</p> <p>Audio File:Select the specific audio file to be played from the dropdown list of uploaded files.</p> <p>Action Times:Specify how many times the audio file should repeat for a single alarm event.</p> <p>Audio Action:Define the trigger logic for the audio play. For each confirmed alarm, the camera will execute the set audio file and repetition count based on the configured schedule.</p>

SD Card Exception

The SD Card Exception module monitors the status of the local storage medium. If the SD card encounters issues that might prevent video or snapshot recording, the camera will trigger an alert based on your selected criteria.

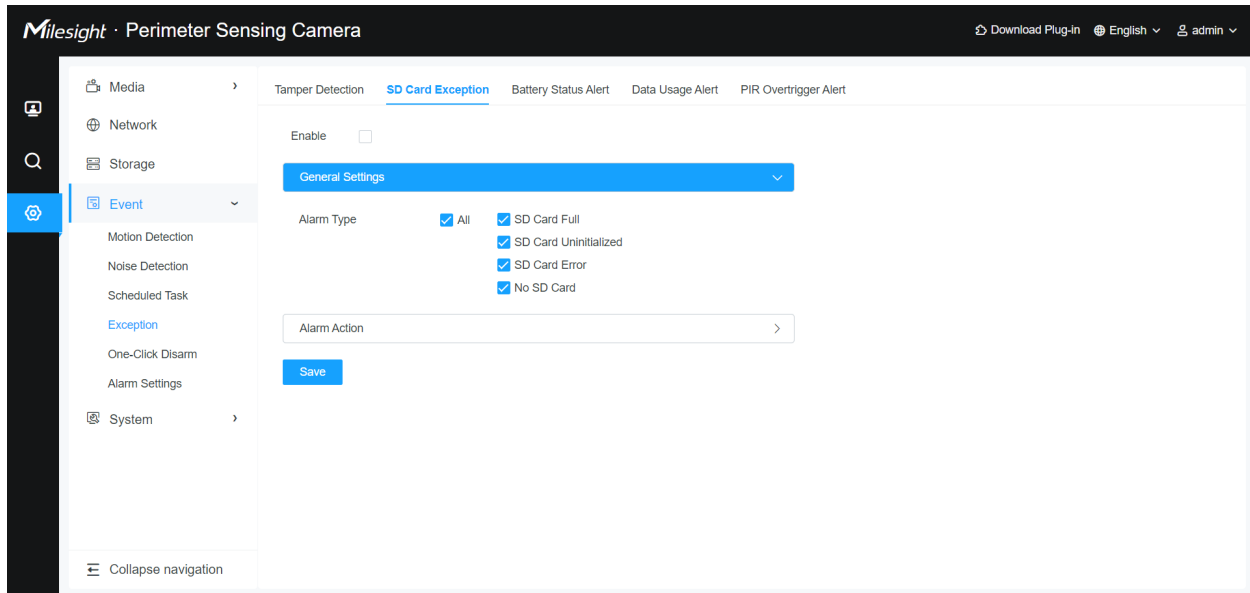

Settings steps are shown as follows:

Step1: Check the checkbox to enable the SD Card Exception.

Table 39. Description of the buttons

Parameters	Function Introduction
Enable	Check the checkbox to enable SD Card Exception function.

[General Settings]

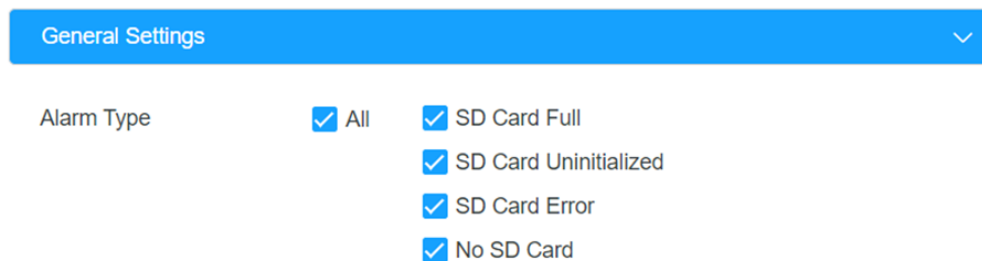

Table 40. Description of the buttons

Parameters	Function Introduction
<p style="text-align: center;">Alarm Type</p>	<p>Select the specific types of SD card issues to monitor:</p> <ul style="list-style-type: none"> • SD Card Full: Triggered when the card reaches its maximum capacity. • SD Card Uninitialized: Triggered if the card is detected but not yet formatted for use. • SD Card Error: Triggered when the card encounters a read/write failure or hardware error. • No SD Card: Triggered if the card is removed or not detected. <p><i>(Select All to enable all monitoring items simultaneously).</i></p>

[Alarm Action]

Step2: Set alarm action. Define what actions the camera takes once a motion event is confirmed.

Alarm Action ▼

Data Push

Enable

Alarm Server ▼

[Alarm Server Management](#)

Data Edit

Code

[Preview](#)

```

1  {
2    "event_id": "$event_id$",
3    "event_type": "$event_type$",
4    "device_name": "$device_name$",
5    "mac_address": "$mac_address$",
6    "sn": "$sn$",
7    "latitude": "$latitude$",
8    "longitude": "$longitude$",
9    "altitude": "$altitude$".

```

Data Edit



```
Code Preview
1 {
2   "event_id": "$event_id$",
3   "event_type": "$event_type$",
4   "device_name": "$device_name$",
5   "mac_address": "$mac_address$",
6   "sn": "$sn$",
7   "latitude": "$latitude$",
8   "longitude": "$longitude$",
9   "altitude": "$altitude$",
10  "time": "$time$",
11  "time_msec": "$time_msec$"
12 }
```

Send Email

Enable

(Please enable the Email.)

Table 41. Description of the buttons

Parameters	Function Introduction
<p style="text-align: center;">Data Push</p>	<p>The camera supports seamless data integration with backend servers (HTTP/HTTPS/MQTT).</p> <p>Alarm Server: Select the target server for data transmission.</p> <p> Note: This feature can only be enabled after the Alarm Server service is configured and tested in Event > Alarm Settings > Alarm Server.</p> <div style="border: 1px solid #ccc; padding: 5px; margin: 10px 0;"> <p style="text-align: right; font-size: 0.8em; color: #007bff;">Preview ×</p> <div style="display: flex; justify-content: space-between;"> <div style="width: 48%;"> <pre>Code Pretty 1 { 2 "event_id": "\$event_id\$", 3 "event_type": "\$event_type\$", 4 "device_name": "\$device_name\$", 5 "mac_address": "\$mac_address\$", 6 "sn": "\$sn\$", 7 "latitude": "\$latitude\$", 8 "longitude": "\$longitude\$", 9 "altitude": "\$altitude\$", 10 "time": "\$time\$", 11 "time_msec": "\$time_msec\$", 12 "retransmit_time": "\$retransmit_time\$", 13 "retransmit_count": "\$retransmit_count\$", 14 "trigger_value": "\$trigger_value\$", 15 "snapshot": "\$snapshot\$" 16 }</pre> </div> <div style="width: 48%;"> <pre>Code 1 { 2 "event_id": "1776468755297", 3 "event_type": "Noise Detection", 4 "device_name": "Perimeter Sensing Camera", 5 "mac_address": "1C:C3:16:54:3F:6E", 6 "sn": "", 7 "latitude": "", 8 "longitude": "", 9 "altitude": "", 10 "time": "2026-04-17 16:32:35", 11 "time_msec": "2026-04-17 16:32:35.297", 12 "retransmit_time": "-", 13 "retransmit_count": 0, 14 "trigger_value": 60, 15 "snapshot": [] 16 { 17 "index": 0, </pre> </div> </div> </div> <p>Data Editor: Allows users to view and customize the data fields pushed to the server in real-time.</p> <p> Note: The data content shown in the editor is a template/example; actual pushed data will vary based on the specific event type.</p>

Parameters	Function Introduction
Send Email	Automatically sends event alerts with attachments to the configured email address.  Note: This feature can only be enabled after the Email service is configured and tested in Event > Alarm Settings > Email .

Battery Status Alert

The Battery Status Alert module ensures the continuous operation of your solar-powered system by monitoring the health and power levels of the internal battery. This allows for proactive maintenance before the device enters low-power protection mode.

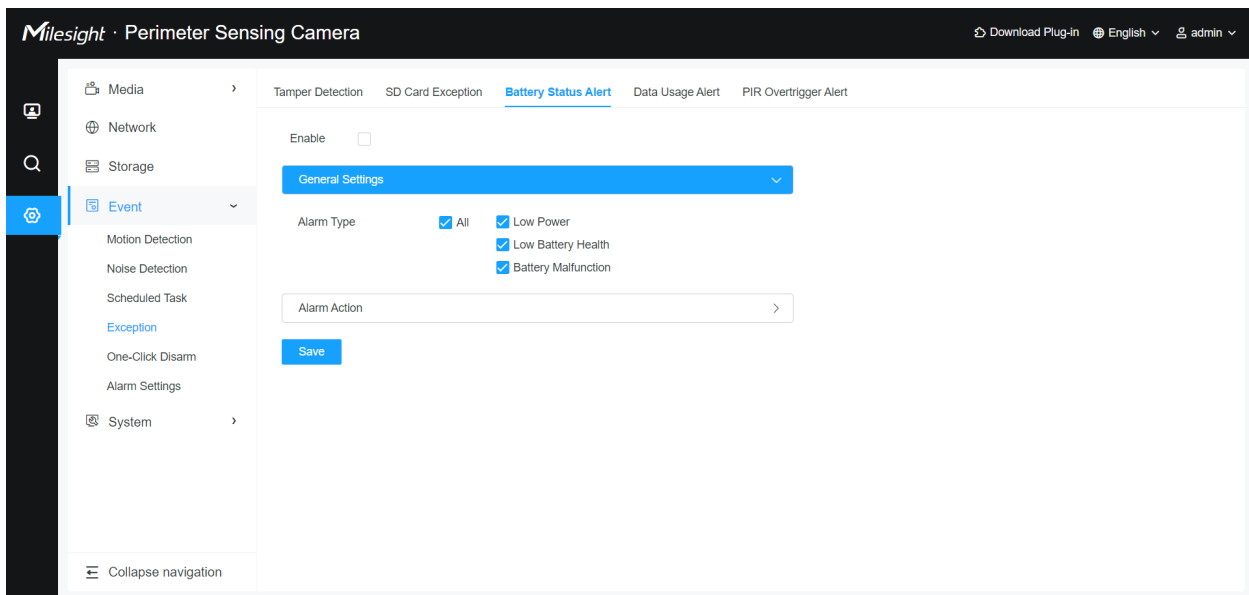

Settings steps are shown as follows:

Step1: Check the checkbox to enable the Battery Status Alert.

Table 42. Description of the buttons

Parameters	Function Introduction
Enable	Check the checkbox to enable Battery Status Alert function.

[General Settings]

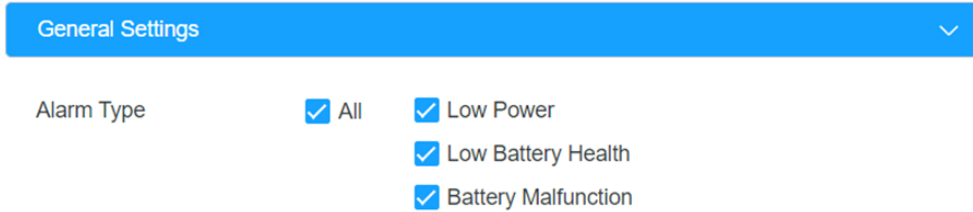

Table 43. Description of the buttons

Parameters	Function Introduction
<p>Alarm Type</p>	<p>Select the battery conditions to monitor:</p> <p>You can check battery status from Battery System (page 85).</p> <ul style="list-style-type: none"> • Low Power: Triggered when the internal battery level drops below 15%. • Low Battery Health: Triggered when the battery's maximum capacity or longevity falls below professional health standards. • Battery Malfunction: Triggered upon detection of hardware-level battery failures. <p>(Select All to enable comprehensive monitoring).</p>

[Alarm Action]

Step2: Set alarm action. Define what actions the camera takes once a motion event is confirmed.

Alarm Action ▼

Data Push

Enable Alarm Server ▼[Alarm Server Management](#)Automatic Retransmission ⓘ (Please insert SD card.)

Data Edit

Code

[Preview](#)

```

1  {
2    "event_id": "$event_id$",
3    "event_type": "$event_type$",
4    "device_name": "$device_name$",
5    "mac_address": "$mac_address$",
6    "sn": "$sn$",
7    "latitude": "$latitude$",
8    "longitude": "$longitude$",
9    "altitude": "$altitude$",
10   "time": "$time$",
11   "time_msec": "$time_msec$",
12   "retransmit_time": "$retransmit_time$",
13   "retransmit_count": "#retransmit_count#",
14   "battery_level": "$battery_level$",
15   "battery_health": "$battery_health$"
16 }

```

```





2    "event_id": "$event_id$",
3    "event_type": "$event_type$",
4    "device_name": "$device_name$",
5    "mac_address": "$mac_address$",
6    "sn": "$sn$",
7    "latitude": "$latitude$",
8    "longitude": "$longitude$",
9    "altitude": "$altitude$",
10   "time": "$time$",
11   "time_msec": "$time_msec$",
12   "retransmit_time": "$retransmit_time$",
13   "retransmit_count": "#retransmit_count#",
14   "battery_level": "$battery_level$",
15   "battery_health": "$battery_health$"
16 }

```

Send Email

Enable (Please enable the Email.)

Table 44. Description of the buttons

Parameters	Function Introduction
<p>Data Push</p>	<p>The camera supports seamless data integration with backend servers (HTTP/HTTPS/MQTT).</p> <p>Alarm Server: Select the target server for data transmission.</p> <p> Note: This feature can only be enabled after the Alarm Server service is configured and tested in Event > Alarm Settings > Alarm Server.</p> <p>Automatic Retransmission:(Requires SD Card) If data push fails due to network issues, the camera will store the data on the SD card and attempt to resend it periodically once the connection is restored.</p> <p> Note: To successfully save captured images or videos to the SD card, you must enable the Data Push function and ensure that "Save All Files to SD Card" is enabled under the Storage settings menu. Without these configurations, files may only be transmitted to the server and not stored locally.</p> <div data-bbox="591 772 1390 1087" style="border: 1px solid #ccc; padding: 5px; margin: 10px 0;"> <div style="background-color: #007bff; color: white; text-align: center; padding: 2px;">Preview ✕</div> <div style="display: flex; justify-content: space-between;"> <div style="width: 48%;"> <p>Code Pretty</p> <pre style="font-family: monospace; font-size: 0.9em;"> 1 { 2 "event_id": "\$event_id\$", 3 "event_type": "\$event_type\$", 4 "device_name": "\$device_name\$", 5 "mac_address": "\$mac_address\$", 6 "sn": "\$sn\$", 7 "latitude": "\$latitude\$", 8 "longitude": "\$longitude\$", 9 "altitude": "\$altitude\$", 10 "time": "\$time\$", 11 "time_msec": "\$time_msec\$", 12 "retransmit_time": "\$retransmit_time\$", 13 "retransmit_count": "\$retransmit_count\$", 14 "trigger_value": "\$trigger_value\$", 15 "snapshot": "\$snapshot_list\$" 16 }</pre> </div> <div style="width: 48%;"> <pre style="font-family: monospace; font-size: 0.9em;"> 1 { 2 "event_id": 1776468755297, 3 "event_type": "Noise Detection", 4 "device_name": "Perimeter Sensing Camera", 5 "mac_address": "1C:C3:16:54:3F:6E", 6 "sn": "", 7 "latitude": "", 8 "longitude": "", 9 "altitude": "", 10 "time": "2026-04-17 16:32:35", 11 "time_msec": "2026-04-17 16:32:35.297", 12 "retransmit_time": "-", 13 "retransmit_count": 0, 14 "trigger_value": 60, 15 "snapshot": [] 16 } 17 "index": 0.</pre> </div> </div> </div> <p>Data Editor: Allows users to view and customize the data fields pushed to the server in real-time.</p> <p> Note: The data content shown in the editor is a template/example; actual pushed data will vary based on the specific event type.</p>
<p>Send Email</p>	<p>Automatically sends event alerts with attachments to the configured email address.</p> <p> Note: This feature can only be enabled after the Email service is configured and tested in Event > Alarm Settings > Email.</p>

Data Usage Alert

The Data Usage Alert module helps you monitor and manage cellular data consumption. By setting a data plan and a pre-alarm threshold, the camera can notify you before your data limit is reached, preventing unexpected service interruptions or overage charges.

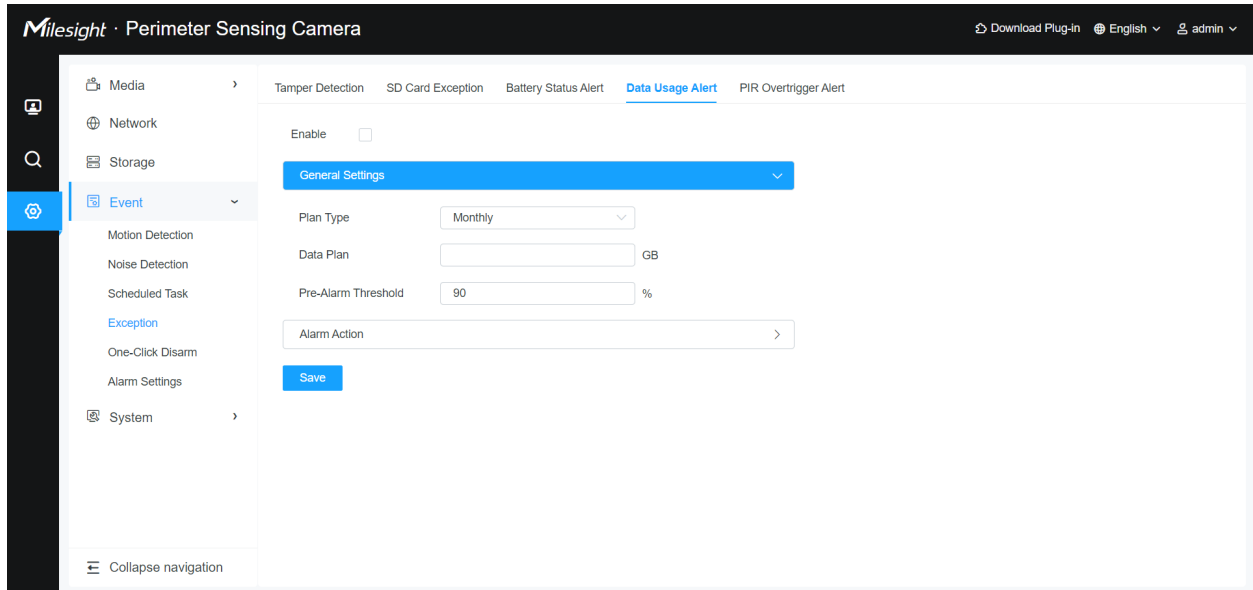

Settings steps are shown as follows:

Step1: Check the checkbox to enable the Data Usage Alert.

Table 45. Description of the buttons

Parameters	Function Introduction
Enable	Check the checkbox to enable Data Usage Alert function.

[General Settings]

General Settings
▼

Plan Type ▼

Monthly

Data Plan GB

[Input Field]

Pre-Alarm Threshold %

90

Table 46. Description of the buttons

Parameters	Function Introduction
Plan Type	Define your data billing cycle (e.g., Monthly or Total).
Data Plan	Enter the total amount of data (in GB) included in your current cellular plan.

Parameters	Function Introduction
Pre-Alarm Threshold	Set a percentage or specific value as a "warning line." The camera will trigger an alert when cumulative data usage reaches this point.

[Alarm Action]

Step2: Set alarm action. Define what actions the camera takes once a motion event is confirmed.

Alarm Action
▼

Data Push

Enable

Alarm Server ▼
[Alarm Server Management](#)

Automatic Retransmission ⓘ (Please insert SD card.)

Data Edit

Code
Preview

```





1  {
2    "event_id": "$event_id$",
3    "event_type": "$event_type$",
4    "device_name": "$device_name$",
5    "mac_address": "$mac_address$",
6    "sn": "$sn$",
7    "latitude": "$latitude$",
```

```
7  "latitude": "$latitude$",
8  "longitude": "$longitude$",
9  "altitude": "$altitude$",
10 "time": "$time$",
11 "time_msec": "$time_msec$",
12 "retransmit_time": "$retransmit_time$",
13 "retransmit_count": "#retransmit_count#",
14 "plan_type": "$plan_type$",
15 "data_plan": "$data_plan$",
16 "data_usage": "$data_usage$"
17 }
```

Send Email

Enable

Table 47. Description of the buttons

Parameters	Function Introduction
<p style="text-align: center;">Data Push</p>	<p>The camera supports seamless data integration with backend servers (HTTP/HTTPS/MQTT).</p> <p>Alarm Server: Select the target server for data transmission.</p> <p> Note: This feature can only be enabled after the Alarm Server service is configured and tested in Event > Alarm Settings > Alarm Server.</p> <p>Automatic Retransmission:(Requires SD Card) If data push fails due to network issues, the camera will store the data on the SD card and attempt to resend it periodically once the connection is restored.</p> <p> Note: To successfully save captured images or videos to the SD card, you must enable the Data Push function and ensure that "Save All Files to SD Card" is enabled under the Storage settings menu. Without these configurations, files may only be transmitted to the server and not stored locally.</p> <div data-bbox="591 722 1386 1031" style="border: 1px solid #ccc; padding: 5px; margin: 10px 0;"> <p style="text-align: right; font-size: small; color: #007bff;">Preview ✕</p> <div style="display: flex; justify-content: space-between;"> <div style="width: 48%;"> <p style="font-size: x-small; margin: 0;">Code Pretty</p> <pre style="font-family: monospace; font-size: x-small; margin: 0;"> 1 { 2 "event_id": "\$event_id\$", 3 "event_type": "\$event_type\$", 4 "device_name": "\$device_name\$", 5 "mac_address": "\$mac_address\$", 6 "sn": "\$sn\$", 7 "latitude": "\$latitude\$", 8 "longitude": "\$longitude\$", 9 "altitude": "\$altitude\$", 10 "time": "\$time\$", 11 "time_msec": "\$time_msec\$", 12 "retransmit_time": "\$retransmit_time\$", 13 "retransmit_count": "\$retransmit_count\$", 14 "trigger_value": "\$trigger_value\$", 15 "snapshot": "\$snapshot_list" 16 }</pre> </div> <div style="width: 48%;"> <p style="font-size: x-small; margin: 0;">Code</p> <pre style="font-family: monospace; font-size: x-small; margin: 0;"> 1 { 2 "event_id": 1776468755297, 3 "event_type": "Noise Detection", 4 "device_name": "Perimeter Sensing Camera", 5 "mac_address": "11C.C3.16.04.3F.6E", 6 "sn": "", 7 "latitude": "", 8 "longitude": "", 9 "altitude": "", 10 "time": "2026-04-17 16:32:35", 11 "time_msec": "2026-04-17 16:32:35.297", 12 "retransmit_time": "-", 13 "retransmit_count": 0, 14 "trigger_value": 60, 15 "snapshot": [] 16 } 17 "index": 0.</pre> </div> </div> </div> <p>Data Editor: Allows users to view and customize the data fields pushed to the server in real-time.</p> <p> Note: The data content shown in the editor is a template/example; actual pushed data will vary based on the specific event type.</p>
<p style="text-align: center;">Send Email</p>	<p>Automatically sends event alerts with attachments to the configured email address.</p> <p> Note: This feature can only be enabled after the Email service is configured and tested in Event > Alarm Settings > Email.</p>

PIR Overtrigger Alert

This feature is designed to detect environmental interference or improper installation. If the PIR sensor is triggered too frequently within a short period, the camera will alert you so you can adjust the installation angle or sensitivity to save power and storage.

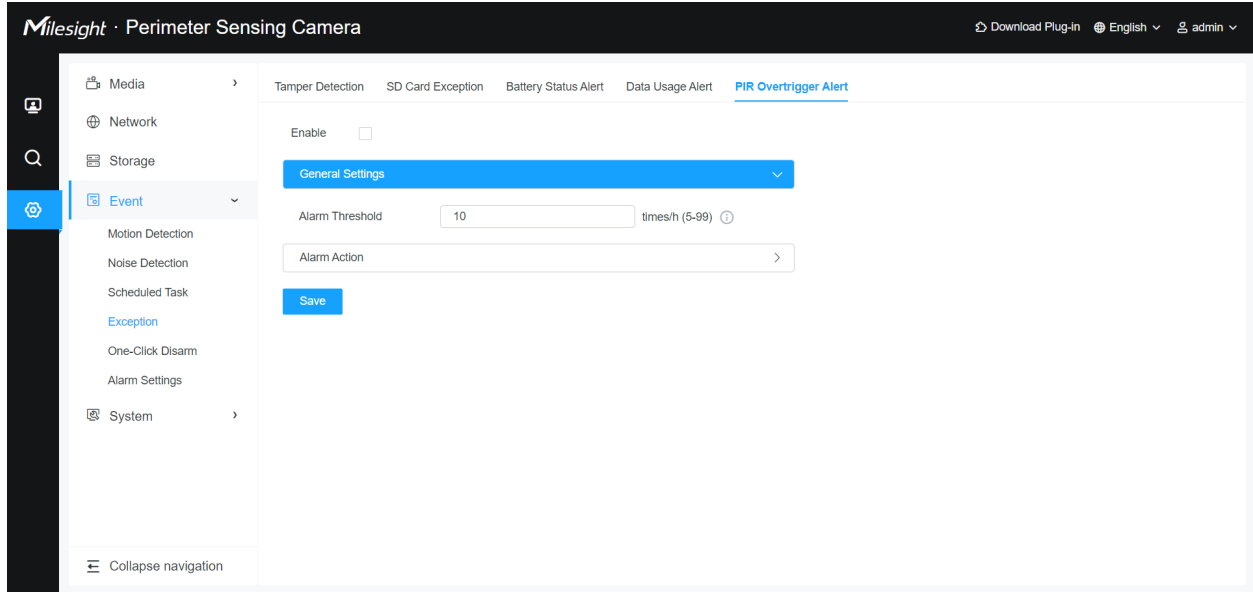

Settings steps are shown as follows:

Step1: Check the checkbox to enable the PIR Overtrigger Alert.

Table 48. Description of the buttons

Parameters	Function Introduction
Enable	Check the checkbox to enable PIR Overtrigger Alert function.

[General Settings]

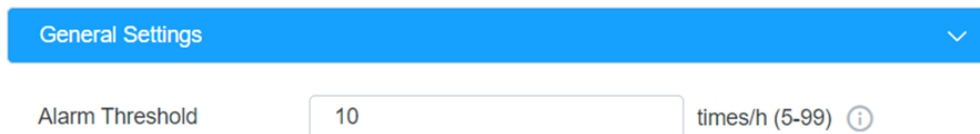

Table 49. Description of the buttons

Parameters	Function Introduction
Alarm Threshold	Set the maximum number of PIR triggers allowed per hour (5~99 times/h). If this limit is exceeded, an alarm will be triggered. (Default: 10)

[Alarm Action]

Step2: Set alarm action. Define what actions the camera takes once a motion event is confirmed.

Alarm Action
▼

Data Push

Enable

Alarm Server Select ▼

[Alarm Server Management](#)

Automatic Retransmission ⓘ (Please insert SD card.)

Data Edit

Code
Preview





```

1  {
2    "event_id": "$event_id$",
3    "event_type": "$event_type$",
4    "device_name": "$device_name$",
5    "mac_address": "$mac_address$",
6    "sn": "$sn$",
7    "latitude": "$latitude$",
8
9    "longitude": "$longitude$",
10   "altitude": "$altitude$",
11   "time": "$time$",
12   "time_msec": "$time_msec$",
13   "retransmit_time": "$retransmit_time$",
14   "retransmit_count": "#retransmit_count#",
15   "trigger_value": "$trigger_value$"
    }
                
```

Send Email

Enable

Table 50. Description of the buttons

Parameters	Function Introduction
<p style="text-align: center;">Data Push</p>	<p>The camera supports seamless data integration with backend servers (HTTP/HTTPS/MQTT).</p> <p>Alarm Server: Select the target server for data transmission.</p> <p> Note: This feature can only be enabled after the Alarm Server service is configured and tested in Event > Alarm Settings > Alarm Server.</p> <p>Automatic Retransmission:(Requires SD Card) If data push fails due to network issues, the camera will store the data on the SD card and attempt to resend it periodically once the connection is restored.</p> <p> Note: To successfully save captured images or videos to the SD card, you must enable the Data Push function and ensure that "Save All Files to SD Card" is enabled under the Storage settings menu. Without these configurations, files may only be transmitted to the server and not stored locally.</p> <div data-bbox="591 724 1386 1035" style="border: 1px solid #ccc; padding: 5px; margin: 10px 0;"> <p style="text-align: right; font-size: small;">Preview ✕</p> <div style="display: flex; justify-content: space-between;"> <div style="width: 48%;"> <p style="font-size: x-small; margin: 0;">Code Pretty</p> <pre style="font-family: monospace; font-size: x-small; margin: 0;"> 1 { 2 "event_id": "\$event_id\$", 3 "event_type": "\$event_type\$", 4 "device_name": "\$device_name\$", 5 "mac_address": "\$mac_address\$", 6 "sn": "\$sn\$", 7 "latitude": "\$latitude\$", 8 "longitude": "\$longitude\$", 9 "altitude": "\$altitude\$", 10 "time": "\$time\$", 11 "time_msec": "\$time_msec\$", 12 "retransmit_time": "\$retransmit_time\$", 13 "retransmit_count": "\$retransmit_count\$", 14 "trigger_value": "\$trigger_value\$", 15 "snapshot": "\$snapshot_list" 16 }</pre> </div> <div style="width: 48%;"> <p style="font-size: x-small; margin: 0;">Code</p> <pre style="font-family: monospace; font-size: x-small; margin: 0;"> 1 { 2 "event_id": "1776468755297", 3 "event_type": "Noise Detection", 4 "device_name": "Perimeter Sensing Camera", 5 "mac_address": "11C:C3:16:54:3F:5E", 6 "sn": "", 7 "latitude": "", 8 "longitude": "", 9 "altitude": "", 10 "time": "2026-04-17 16:32:35", 11 "time_msec": "2026-04-17 16:32:35.297", 12 "retransmit_time": "-", 13 "retransmit_count": 0, 14 "trigger_value": 60, 15 "snapshot": [] 16 { 17 "index": 0, </pre> </div> </div> </div> <p>Data Editor: Allows users to view and customize the data fields pushed to the server in real-time.</p> <p> Note: The data content shown in the editor is a template/example; actual pushed data will vary based on the specific event type.</p>
<p style="text-align: center;">Send Email</p>	<p>Automatically sends event alerts with attachments to the configured email address.</p> <p> Note: This feature can only be enabled after the Email service is configured and tested in Event > Alarm Settings > Email.</p>

One-Click Disarm

The One-Click Disarm feature is designed for scenarios where continuous 24/7 alerting is not required, such as construction sites or farms during working hours. It allows users to quickly suppress alarm linkage actions (notifications and audio alerts) during specific periods.

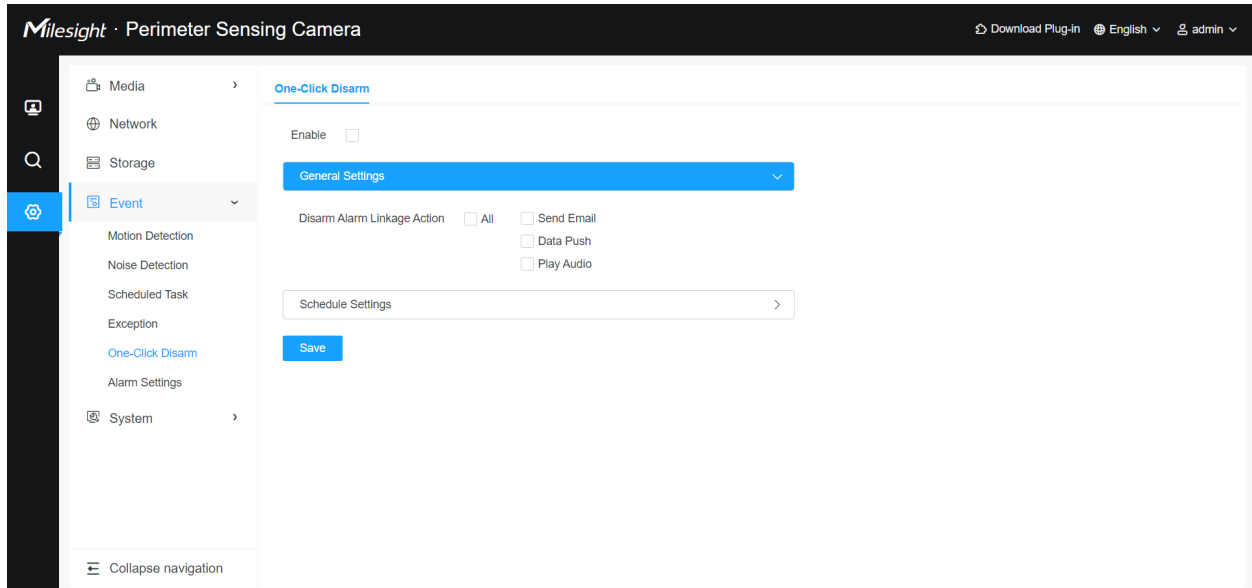

Settings steps are shown as follows:

Step1: Check the checkbox to enable the One-Click Disarm.

Table 51. Description of the buttons

Parameters	Function Introduction
Enable	Check the checkbox to enable One-Click Disarm function.

[General Settings]

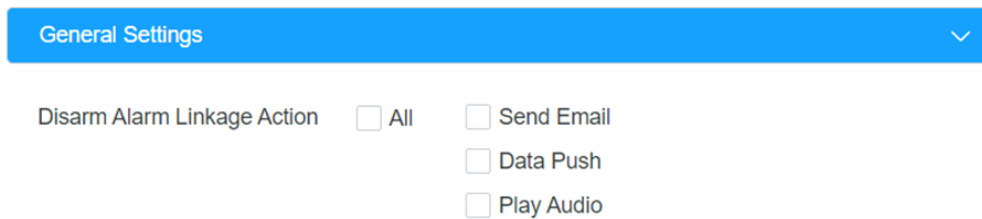

Table 52. Description of the buttons

Parameters	Function Introduction
<p>Disarm Alarm Linkage Action</p>	<p>Select the specific actions to be suppressed during the disarmed period. When an item is checked, the corresponding action will not be triggered even if an event occurs.</p> <ul style="list-style-type: none"> • Data Push: Suppresses data transmission to the server for all events. • Send Email: Suppresses email notifications for all events. • Play Audio: Suppresses external speaker alerts (Motion, Noise, and Tamper events). <p><i>(Select All to suppress all linkages simultaneously).</i></p>

[Schedule Settings]

Step2: Set One-Click Disarm schedule;



Table 53. Description of the buttons

Parameters	Function Introduction
	<p>Copy the schedule area to another date.</p>

Parameters	Function Introduction
Select All	Select all schedule.
Clear All	Clear all schedule.

Alarm Settings

Alarm Server

The Alarm Server configuration allows the camera to push event data, snapshots, and video clips to a remote server. You can configure up to **three** servers for each protocol type to ensure data redundancy and integration with different management platforms.

The screenshot displays the 'Alarm Server' configuration interface. The top navigation bar includes 'Milesight · Perimeter Sensing Camera', 'Download Plug-in', 'English', and 'admin'. The left sidebar shows a menu with 'Event' selected, containing options like 'Motion Detection', 'Noise Detection', 'Scheduled Task', 'Exception', 'One-Click Disarm', and 'Alarm Settings'. The main content area is titled 'Alarm Server' and has a sub-tab 'Email'. It is divided into two sections: 'HTTP/HTTPS' and 'MQTT'. Each section has 'Add' and 'Delete' buttons and a table with columns for Protocol Type, Destination IP/Host Name, Port, Path (for HTTP/HTTPS) or Topic (for MQTT), and Operation. Both tables currently show 'No Data'.

[HTTP/HTTPS]

Use this section to manage standard web-based alarm servers.

Add Alarm Server
×

Protocol Type

Destination IP/Host Name

Path

Port (1~65535)

User Name

Password

Save
Test
Cancel

Table 54. Description of the buttons

Parameters	Function Introduction
Protocol Type	Choose between HTTP or HTTPS . (HTTPS provides encrypted transmission; default ports are 80 for HTTP and 443 for HTTPS).
Destination IP/Host Name	Enter the target server's IP address or domain name (up to 127 characters).
Path	Define the specific endpoint path on your server (e.g., /api/v1/event).
Port	Enter the communication port (1~65535).
User Name / Password	Enter credentials if your server requires basic authentication.
Test	Click to verify the connection. The system will attempt to push a test message and return a success/failure status.

[MQTT/MQTTS]

MQTT is recommended for real-time messaging and integration with IoT platforms.

Add Alarm Server
×

Protocol Type MQTT ▾

Destination IP/Host Name

Port (1~65535)

User Name

Password

TLS

Topic

Save
Test
Cancel

Table 55. Description of the buttons

Parameters	Function Introduction
Destination IP/Host Name	Enter the target server's IP address or domain name (up to 127 characters).
Port	Enter the communication port (1~65535).
User Name / Password	Enter credentials if your server requires basic authentication.
TLS	Enable this to use secure MQTT. You must select a Server Certificate managed in the <i>Security</i> section.
User Name / Password	Enter credentials if your server requires basic authentication.
Topic	Define the prefix for all MQTT messages. The default is 4GSolarPerimCam. <ul style="list-style-type: none"> • <i>Events</i>: [Prefix]/snapshot • <i>Status</i>: [Prefix]/status • <i>Control</i>: [Prefix]/wake/[MAC]
Test	Click to verify the connection. The system will attempt to push a test message and return a success/failure status.

Email

Alarm video files can be sent to specific mail account through SMTP server. You must configure the email settings correctly before using it.

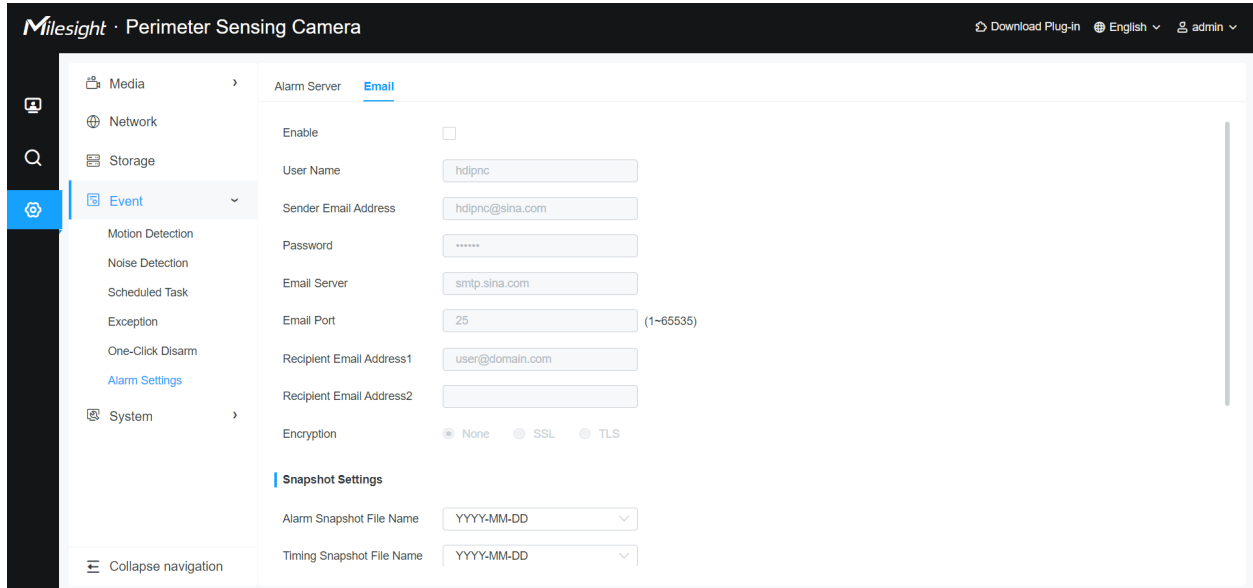



Table 56. Description of the buttons

Parameters	Function Introduction
Enable	Check the checkbox to enable Email function.
User Name	The sender's name. It is usually the same as the account name.
Sender Email Address	Email address to send video files attached emails.
Password	The password of the sender.
Email Server	The email server IP address or host name(e.g. smtp.gmail.com).
Email Port	The default TCP/IP port for SMTP is 25(not secured). For SSL/TLS port, it depends on the mail you use.
Recipient Email Address1	Email address to receive video files.
Recipient Email Address2	Email address to receive video files.

Parameters	Function Introduction
Encryption	Check the checkbox to enable SSL or TLS if it is required by the SMTP server.
Snapshot Settings	<p>Alarm Snapshot File Name: Default(YYYY-MM-DD) /MM-DD-YYYY/ DD-MM-YYYY/ Add prefix/ Overwrite with the base file name/ Customize are available.</p> <p>Timing Snapshot File Name: Default(YYYY-MM-DD) /MM-DD-YYYY/ DD-MM-YYYY/ Add prefix/ Overwrite with the base file name/ Customize are available.</p>
Record Settings	Alarm Record File Name: Default(YYYY-MM-DD) /MM-DD-YYYY/ DD-MM-YYYY/ Add prefix/ Overwrite with the base file name/ Customize are available.
Third-Party Platform Compatibility Settings	<p>Platform Type:</p> <p>GeneralUse the standard system profile. This is optimized for most common public and corporate email services.</p> <p>Custom1Use a dedicated custom profile. Select this if you need to maintain a separate set of configuration parameters for a specific private or non-standard mail server.</p>
	Save the configuration.
	Test whether the configuration is successful.

Chapter 9. System

Work Mode

The Work Mode defines the camera's operation logic and power consumption strategy. Switching between modes will automatically adjust the available features in the **Event** module to optimize performance and battery life.

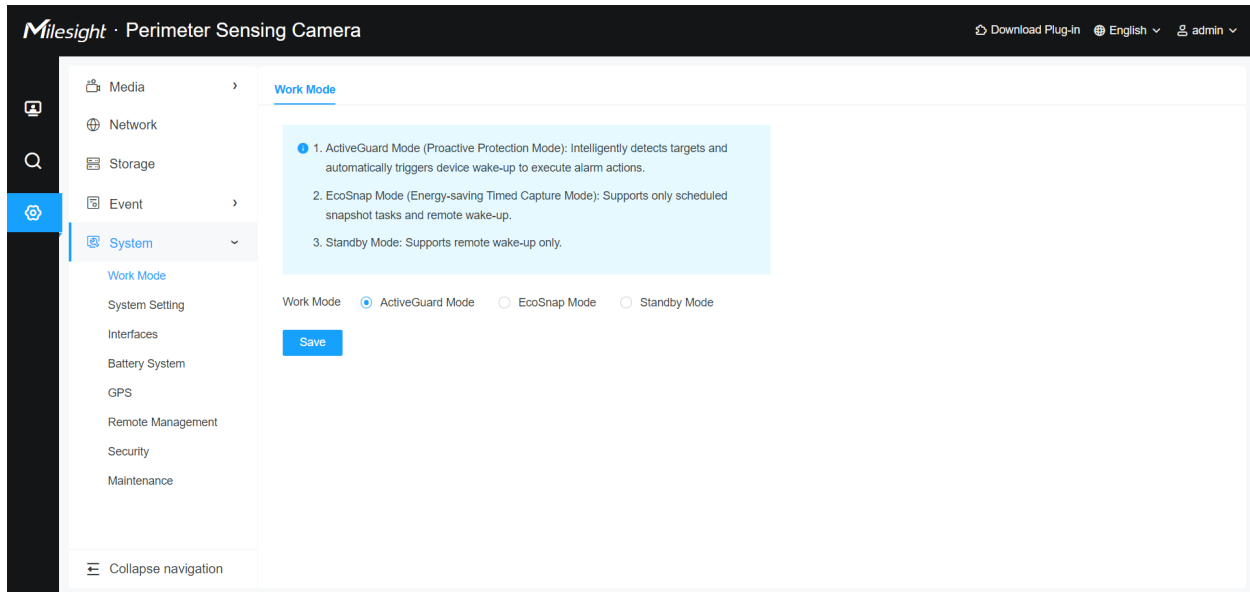

Working Mode	PIR	AOV	Scheduled Image	Exception Event	Remote Wake-up
ActiveGuard Mode	✓	✓	✓	✓	✓
EcoSnap Mode	×	×	✓	✓	✓
Standby Mode	×	×	×	✓	✓

Table 57. Description of the buttons

Parameters	Function Introduction
ActiveGuard Mode	Proactive Protection Mode (Default). The camera intelligently detects targets (PIR, Noise, etc.) and automatically wakes up to execute configured alarm actions. This mode offers the highest level of security.

Parameters	Function Introduction
EcoSnap Mode	Energy-saving Timed Capture Mode. In this mode, proactive event detection (like Motion/Noise) is disabled. The camera only supports Scheduled Task (timed snapshots) and manual remote wake-up.
Standby Mode	Ultra-low Power Mode. All automatic detection and scheduled tasks are disabled. The camera remains in deep sleep and only supports Manual Remote Wake-up via the app or platform.
	Save the configuration.

System Setting

System Info

The System Information page provides essential hardware and software details of the camera. This information is crucial for technical support and device identification within your network.

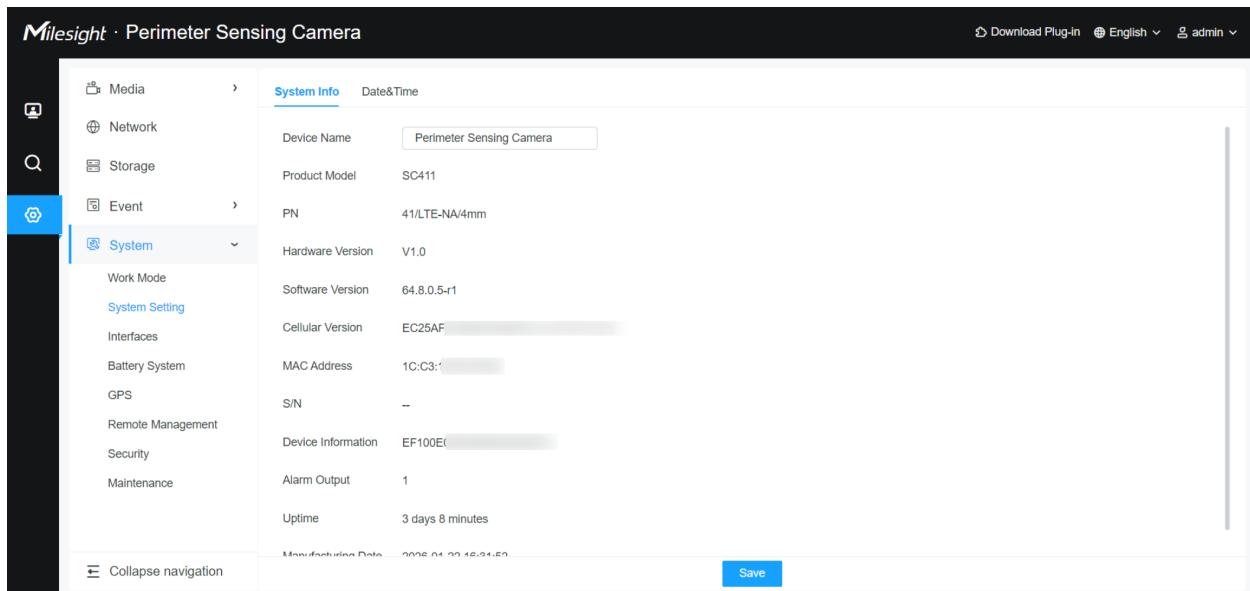

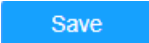
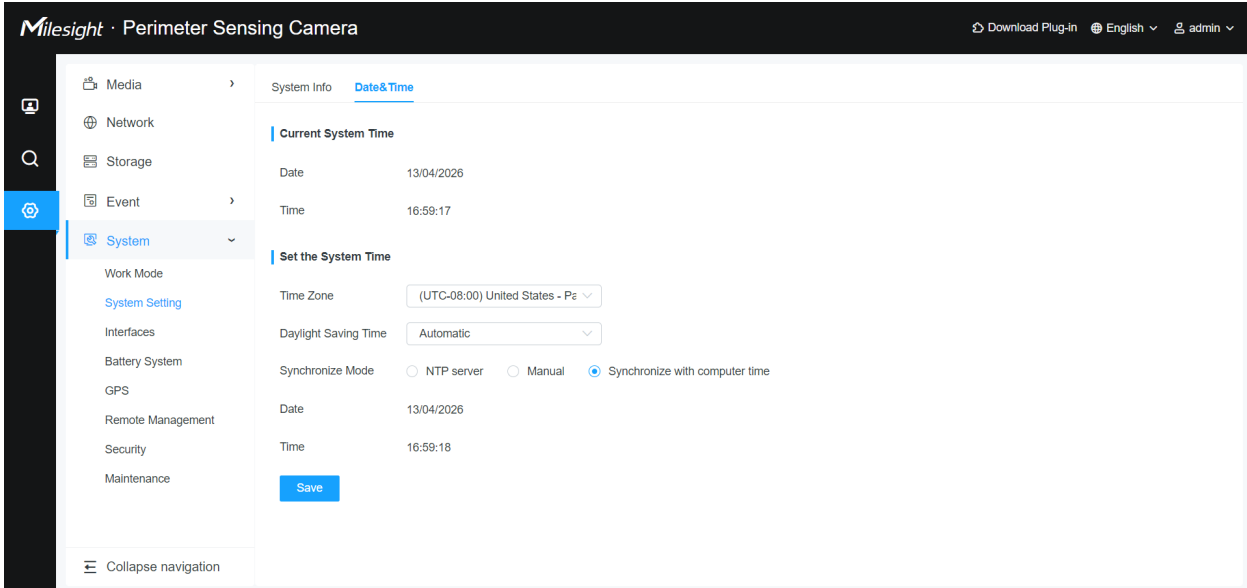

Table 58. Description of the buttons

Parameters	Function Introduction
Device Name	Custom name for your camera (e.g., "North Gate"). Max 31 characters. If left empty, the system will prompt: <i>Required Field.</i>

Parameters	Function Introduction
Product Model	The product model of the camera.
PN (Part Number)	Displays the specific product configuration (e.g., 42/LTE-EU/4mm).
Hardware Version	The hardware version of the camera.
Software Version	The software version of the camera can be upgraded.
Cellular Version	Displays the internal 4G module's firmware version.
MAC Address	Media Access Control address.
S/N	The unique serial number assigned to the device.
Device Information	The device information, including information about alarm I/O and clipper chip.
Alarm Output	The number of Alarm Output interface.  Note: The Alarm Output will appear only when the camera have alarm input/output interface.
Uptime	Displays the total time the device has been running since its last reboot.
Manufacturing Date	Displays the production or build timestamp of the device firmware.
	Save the configuration.

Date&Time



The screenshot shows the 'Date & Time' configuration page in the Milesight Perimeter Sensing Camera web interface. The page is titled 'System Info Date & Time' and displays the current system time (Date: 13/04/2026, Time: 16:59:17) and options to set the system time (Time Zone: (UTC-08:00) United States - Pe, Daylight Saving Time: Automatic, Synchronize Mode: Synchronize with computer time). A Save button is visible at the bottom.

Table 59. Description of the buttons

Parameters	Function Introduction
Current System Time	Current date&time of the system.
Set the System Time	Time Zone: Choose a time zone for your location.
	Daylight Saving time: Enable the daylight saving time.
	Synchronize Mode: NTP server, Manual and Synchronize with computer time are optional.
	NTP server: Input the address of NTP server. NTP Sync: Regularly update your time according to the interval time. Manual: Set the system time manually. Synchronize with computer time: Synchronize the time with your computer.
<div style="background-color: #007bff; color: white; padding: 5px; display: inline-block; border-radius: 3px;">Save</div>	Save the configuration.

Interfaces

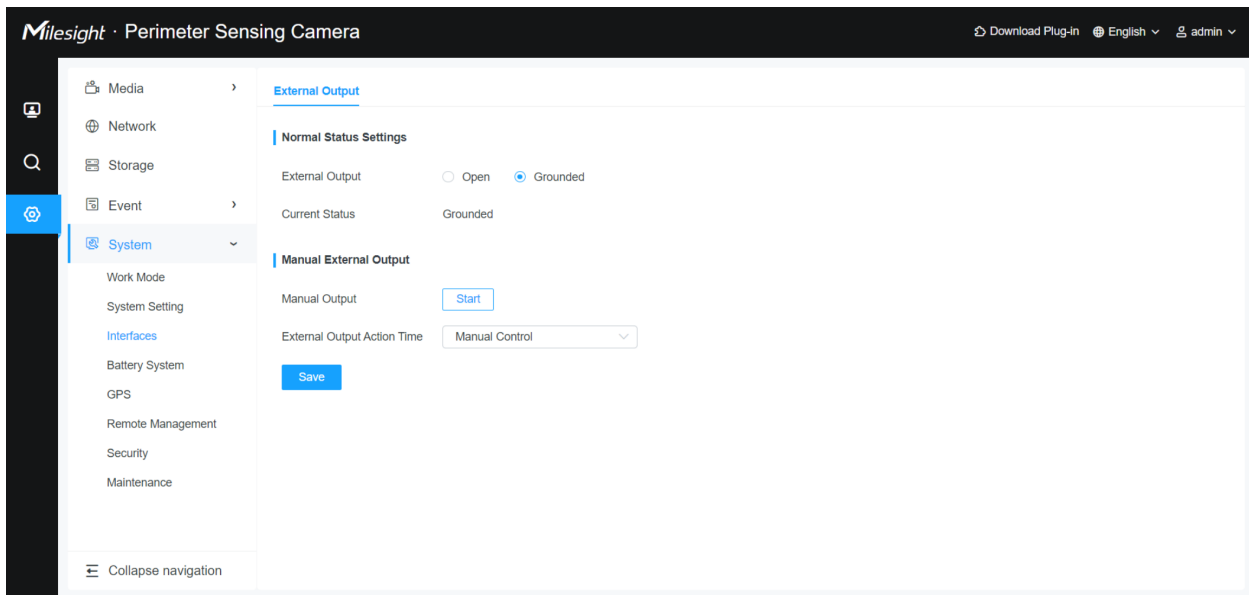
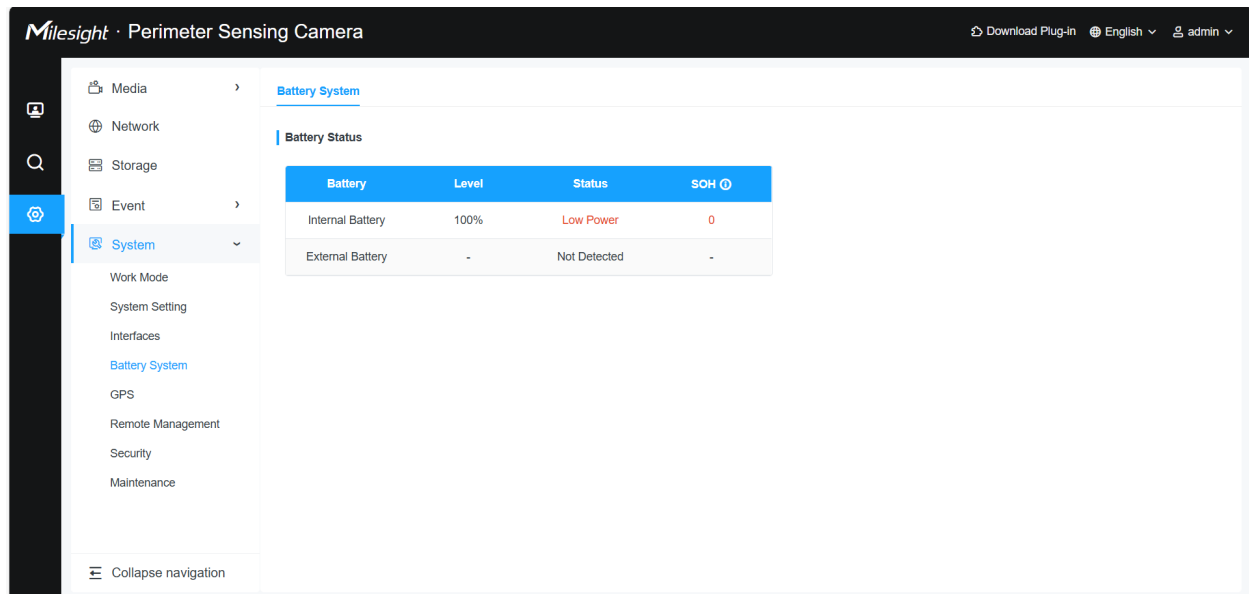

Table 60. Description of the buttons

Parameters	Function Introduction
Normal Status Settings	<p>External Output Displays the current configuration and allows you to set the default state.</p> <p>Current Status Displays the real-time status of the output port (Grounded or Open).</p>
Manual External Output	<p>Manual Output: Click [Start] to manually activate the external output. The port will switch its state (e.g., from Open to Grounded) immediately.</p> <p>External Output Action Time: This setting defines how long the external output remains active once it is triggered by an event (such as Motion Detection) or a manual command.</p> <p>Manual Control: The output will stay active indefinitely until it is manually stopped by the user via the web interface or app.</p> <p>Customize: Allows you to input a specific duration (in seconds or minutes) tailored to your needs.</p> <p>10s / 1min / 5min / 10min: Predefined intervals. After the selected time elapses, the output will automatically revert to its Normal Status.</p>
<div style="background-color: #007bff; color: white; padding: 5px 15px; display: inline-block; border-radius: 3px;">Save</div>	Save the configuration.

Battery System

You can check the battery status and battery health in this module.



The screenshot shows the Milesight Perimeter Sensing Camera web interface. The top navigation bar includes the Milesight logo, the product name "Perimeter Sensing Camera", and options for "Download Plug-In", "English", and "admin". The left sidebar contains a navigation menu with categories like Media, Network, Storage, Event, and System. The "System" menu is expanded, showing options like Work Mode, System Setting, Interfaces, Battery System (highlighted), GPS, Remote Management, Security, and Maintenance. The main content area is titled "Battery System" and "Battery Status". It features a table with the following data:

Battery	Level	Status	SOH
Internal Battery	100%	Low Power	0
External Battery	-	Not Detected	-

This module monitors the real-time power levels and health status of both internal and external battery systems. The device utilizes **RS485 communication** to automatically detect compatible external solar battery components.

 **Note:** The **RS485 communication** feature is **only compatible with the S100 Solar Panel Modules** (S100B96/S100B55).

[Battery Status]

Table 61. Description of the buttons

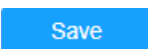
Parameters	Function Introduction
<p>Battery Status</p>	<p>Internal Battery: Displays the real-time Level, SOH (State of Health), and Status of the built-in battery.</p> <p>External Battery</p> <ul style="list-style-type: none"> • Detected: Displays the current data from the external solar battery system. • Not Detected: Displayed if no external system is connected via RS485 (or if using a standard DC power source without data communication). <p>Level: This column indicates the current battery level. It shows the remaining charge as a percentage, helping you monitor when the battery needs recharging or replacing.</p> <p>Status: This column indicates the current status of the battery.</p> <ul style="list-style-type: none"> • Running: The battery is operating normally. • Low Power: The battery is running low on charge and needs recharging soon. • Malfunction: There is a problem with the battery, and it may not be functioning correctly. • Not Detected: The battery is not detected by the system. • HighTempProtect: The battery is in a high-temperature protection mode to prevent overheating. • LowTempProtect: The battery is in a low-temperature protection mode to prevent damage from cold temperatures. <p>SOH: SOH (State of Health) refers to the health status of a battery.</p>
<p></p>	<p>Save the configuration.</p>

GPS

The GPS module provides the camera's geographical coordinates (Latitude, Longitude, and Altitude). This data is essential for asset tracking, map integration, and synchronized event reporting.

 **Note:**

1. **Outdoor Use Only:** The GPS module requires a clear, unobstructed view of the sky to lock onto satellite signals. It will **not function indoors** or in areas with significant overhead obstructions (such as deep canyons or under heavy metal roofing).
2. **Initial Positioning:** When the camera is first powered on outdoors, it may take a few minutes to acquire a satellite fix and update the coordinates in the interface.

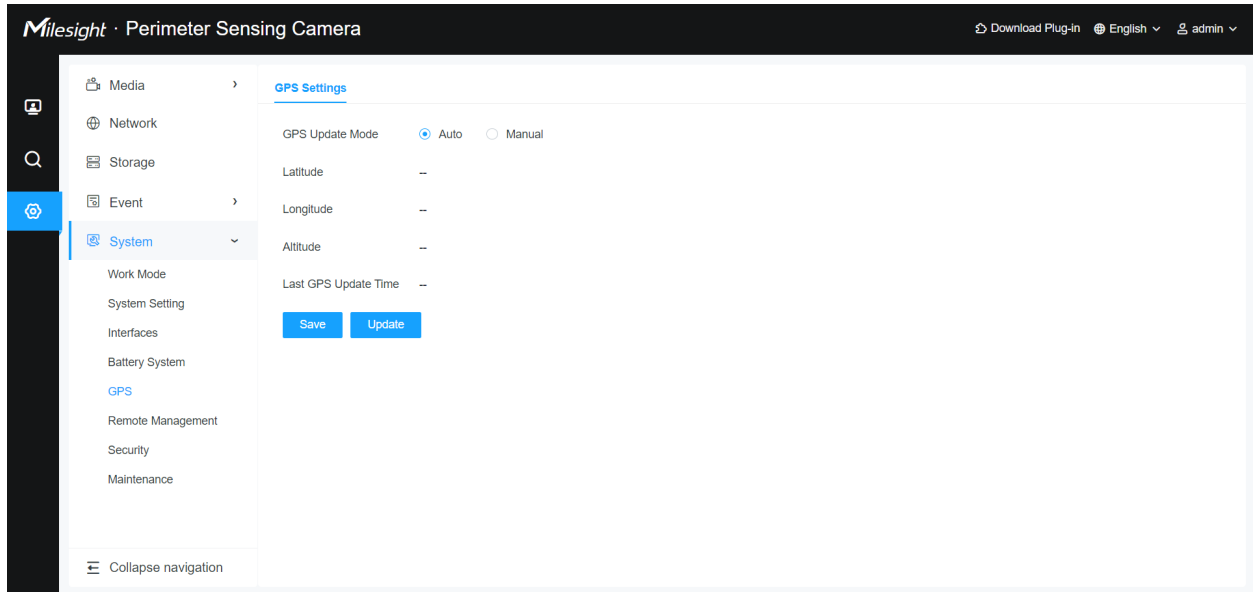
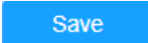
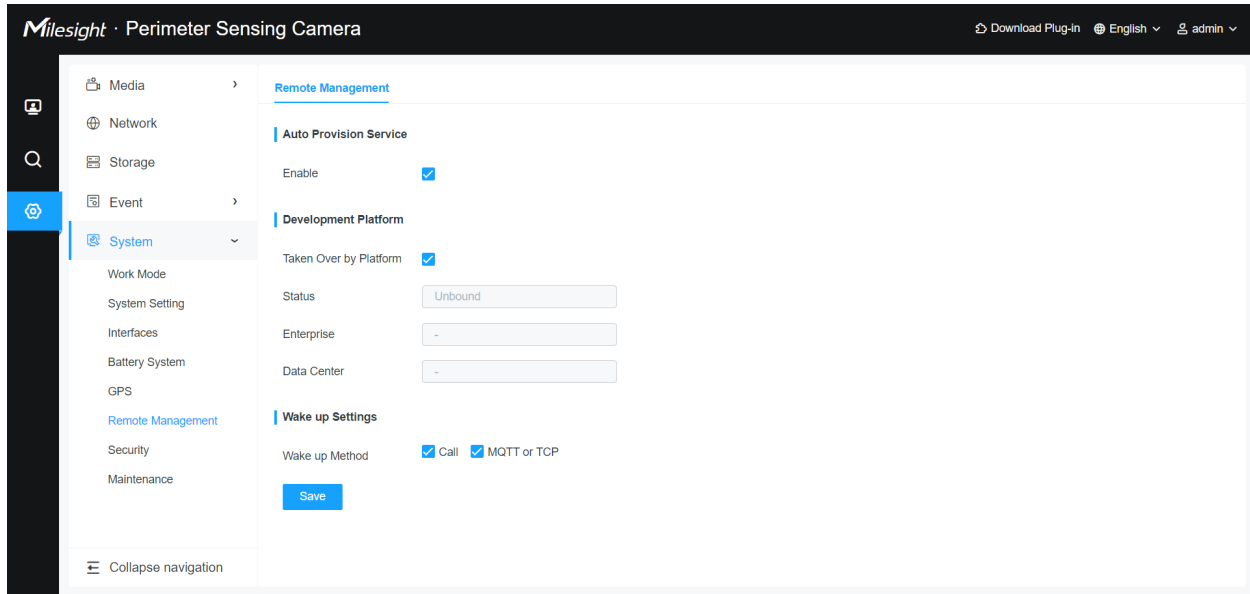

Table 62. Description of the buttons

Parameters	Function Introduction
<p style="text-align: center;">GPS Update Mode</p>	<p>Choose how the camera acquires its location data.</p> <p>AutoThe system automatically retrieves the latest location data from the built-in GPS module. Recommended for mobile installations or initial setups.</p> <p>In Auto mode, all coordinates are read-only and updated by the system.</p> <ul style="list-style-type: none"> • Latitude / Longitude: Displays the current horizontal and vertical coordinates in degrees (°). • Altitude: Displays the elevation above sea level. • Last GPS Update Time: Shows the timestamp of the most recent successful GPS fix. • [Update] Button: Click to trigger an immediate GPS refresh. The system will display "Operating, Please wait..." while it re-acquires the signal. <p>ManualAllows you to manually input specific coordinates. This is ideal for stationary installations where GPS signals may be unstable or where specific professional mapping data is required.</p> <p>In Manual mode, you can customize the location data. The system uses a decimal degree format (consistent with Google Maps) for easier data entry.</p> <p>Latitude-90.000000 ~ 90.000000</p> <p>Longitude-180.000000 ~ 180.000000</p> <p>Altitude-11000.0 ~ 90000.0</p>
<p style="text-align: center;"></p>	<p>Save the configuration.</p>

Remote Management



The Remote Management section allows you to configure various settings that enable remote control and management of your security camera. This includes enabling the Auto Provision Service, Development Platform, and configuring Wake Up Settings.

You can use the Milesight Development Platform for remote and bulk management of devices. Platform address:

<https://account.milesight.com/login>

For instructions on how to add a device, please refer to the platform manual:

<https://www.milesight.com/docs/en/development-platform/introduction/connect-a-device.html>

Auto Provision Service

- **Enable Auto Provision Service:**
 - Enabling this option means that the camera will automatically obtain pre-configuration from the Milesight Development Platform after rebooting.

Development Platform

- **Enable Development Platform:**
 - Enabling this option allows the Milesight Development Platform to modify camera settings. Users can then more conveniently modify camera settings remotely in bulk via the Milesight Development Platform.

Table 63. Description of the buttons

Parameters	Function Introduction
Taken Over by Platform	Toggle to allow or restrict the device from connecting to the management platform. (Default: Enabled)
Status	Displays the real-time connection status: <ul style="list-style-type: none"> • Unbound: Device has not been added to any account. • Online: Device is successfully connected to the platform. • Offline: Device is registered but currently disconnected.
Enterprise	Displays the enterprise.
Taken Over by Platform	Toggle to allow or restrict the device from connecting to the management platform. (Default: Enabled)
Data Center	Displays the region of the connected server (e.g., EU).

Wake Up Settings

- **Wake Up Method:**
 - This setting determines how the camera will wake up from a low-power state.
 - **Call:** The camera can be woken up by making a call.
 - **MQTT or TCP:** The camera can be woken up using MQTT (Message Queuing Telemetry Transport) protocol.

Security

User

The screenshot displays the Misesight Perimeter Sensing Camera web interface. The top navigation bar includes the logo, the title "Perimeter Sensing Camera", and options for "Download Plug-In", "English", and a user profile "admin". The left sidebar contains a search icon and a list of system categories: Media, Network, Storage, Event, and System (which is expanded). The main content area is titled "User" and includes sub-sections for "Security Service", "Certificate Management", and "About". Under "Security Service", there is a "Security Question" section with an "Edit" button. Below that is the "Account Management" section, which contains a table with the following data:

ID	User Name	Privilege	Operation
1	admin	Administrator	

At the bottom of the sidebar, there is a "Collapse navigation" button.

Table 64. Description of the buttons

Parameters	Function Introduction
<p>Security Question</p>	<p>Click "Edit" button to set three security questions for your camera. In case that you forget the password, you can click "Forget Password" button on login page to reset the password by answering three security questions correctly.</p> <div data-bbox="532 411 1330 1058" style="border: 1px solid #ccc; padding: 10px; background-color: #f9f9f9;"> <div style="background-color: #007bff; color: white; padding: 5px; display: flex; justify-content: space-between; align-items: center;"> Security Question Settings × </div> <div style="margin-top: 10px;"> <p>Admin Password* <input type="password"/></p> <p>Security Question1 <input type="text" value="What's your father's name?"/></p> <p>Answer1* <input type="text"/></p> <p>Security Question2 <input type="text" value="What's your father's name?"/></p> <p>Answer2* <input type="text"/></p> <p>Security Question3 <input type="text" value="What's your father's name?"/></p> <p>Answer3* <input type="text"/></p> <div style="display: flex; justify-content: center; gap: 20px; margin-top: 10px;"> Save Cancel </div> </div> </div> <p>There are twelve default questions below, you can also customize the security questions.</p> <div data-bbox="532 1171 1330 1619" style="border: 1px solid #ccc; padding: 10px; background-color: #f9f9f9;"> <div style="border-bottom: 1px solid #ccc; padding-bottom: 5px;"> <input type="text" value="What's your father's name?"/> </div> <div style="display: flex; gap: 10px; margin-top: 5px;"> <div style="border: 1px solid #ccc; padding: 5px; width: 45%;"> <p style="background-color: #007bff; color: white; padding: 2px 5px; margin: -5px -5px 5px -5px;">What's your father's name?</p> <p>What's your favorite sport?</p> <p>What's your mother's name?</p> <p>What's your mobile number?</p> <p>What's your first pet's name?</p> <p>What's your favorite book?</p> <p>What's your favorite game?</p> </div> <div style="border: 1px solid #ccc; padding: 5px; width: 45%;"> <p>What's your favorite food?</p> <p>What's your lucky number?</p> <p>What's your favorite color?</p> <p style="background-color: #007bff; color: white; padding: 2px 5px; margin: -5px -5px 5px -5px;">What's your best friend's name?</p> <p>Where did you go on your first trip?</p> <p>Customized Question</p> </div> </div> </div>

Parameters	Function Introduction
Account Management	<p>Edit:</p> <p>Admin Password: You can change the password only after you enter the correct admin password.</p> <p>New Password: Input password for the account.</p> <p>Confirm: Confirm the password.</p> <p>For the default admin account, you can only change the password, and it cannot be deleted.</p>

Security Service

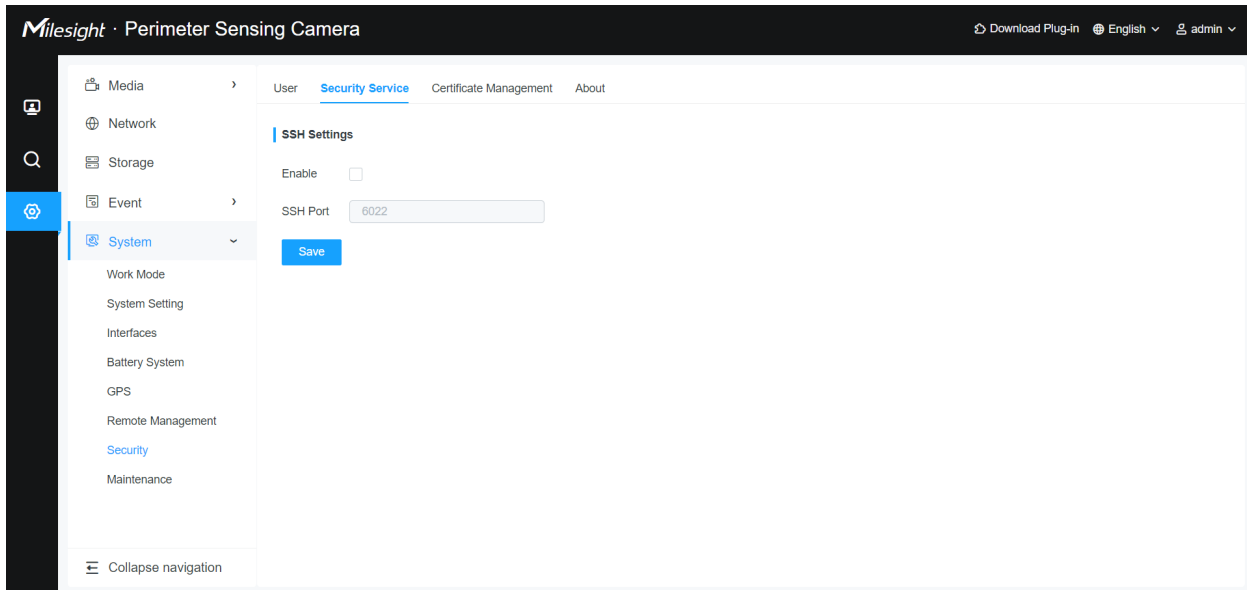
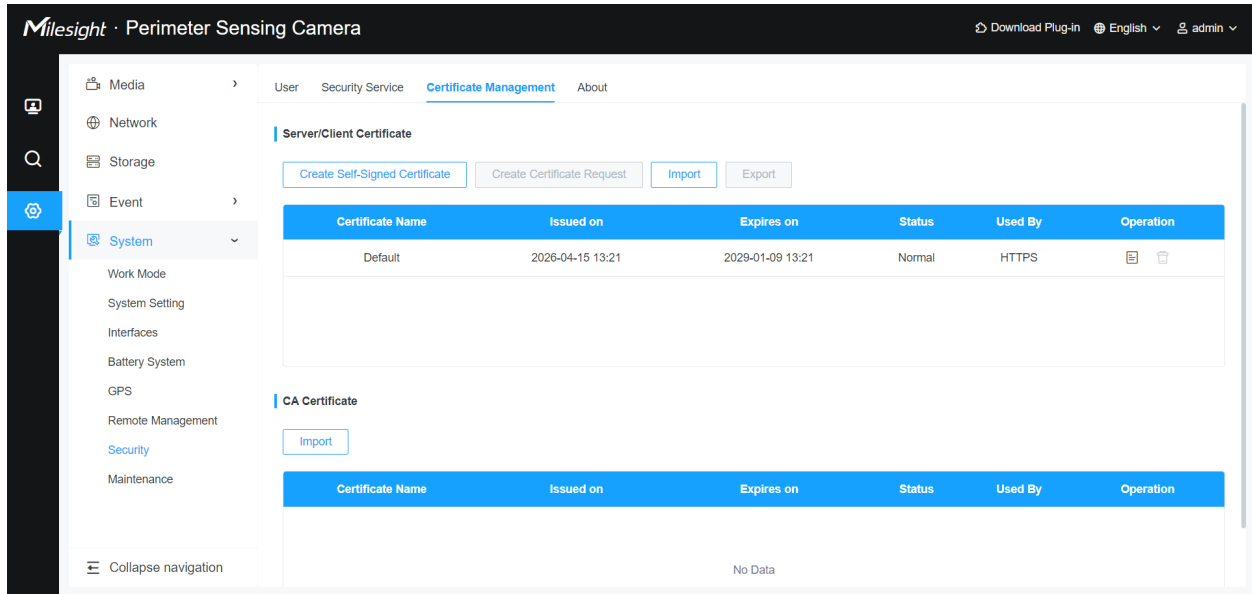

Table 65. Description of the buttons

Parameters	Function Introduction
SSH Settings	Secure Shell (SSH) has many functions: it can replace Telnet and also provides a secure channel for FTP, POP, even for PPP.

Certificate Management

The Certificate Management page allows you to manage **Server/Client Certificates** and **CA Certificates**. These are essential for establishing secure, encrypted connections between the camera and web browsers or remote servers.



[Server/Client Certificate]

This list manages certificates used by the camera to identify itself to other devices.

Table 66. Description of the buttons

Parameters	Function Introduction
<p>Create Self-Signed Certificate</p>	<p>Generate a certificate signed by the device itself for immediate use without third-party authorization.</p> <p>Certificate NameA unique alias for the certificate. Max 64 characters. Cannot contain the & character.<u>Local_Admin_Cert</u></p> <p>Public Key LengthDetermines encryption strength. 2048 is the recommended industry standard for security.<u>2048</u></p> <p>CountryThe 2-letter ISO 3166 country code. Must be two uppercase letters.<u>CN, US, UK</u></p> <p>Domain/IPThe primary address used to access the camera. Crucial: This must match the IP or Domain in your browser's address bar.<u>192.168.1.100</u></p> <p>Validity PeriodHow long the certificate remains valid. Range: 1–5000 days.<u>3650</u></p> <p>PasswordAn optional password to protect the private key. <i>(Optional)</i></p> <p>Province/StateThe state or province where the device is located.<u>Fujian</u></p> <p>LocalityThe city or district where the device is located.<u>Xiamen</u></p> <p>Organization UnitThe department or division (e.g., IT, Security).<u>IT Dept</u></p> <p>OrganizationYour company or legal entity name.<u>TrafficX Tech</u></p> <p>EmailContact email address for the certificate administrator.<u>admin@example.com</u></p>

Parameters	Function Introduction
Create Certificate Request (CSR)	<p>Select an existing (or expired) certificate to generate a signing request. This is used to obtain a professional signature from a Certificate Authority (CA) while retaining the original Domain/IP info.</p> <p>Certificate NameAutomatically populated from the selected certificate. This field is read-only to maintain consistency.</p> <p>CountryThe 2-letter ISO country code.US</p> <p>Domain/IPThe access address for the camera.</p> <p>Province/StateThe state or province name.</p> <p>LocalityThe city or district name.</p> <p>OrganizationYour company or entity name.</p> <p>Organization UnitThe specific department name.</p> <p>EmailThe administrator's contact email.</p>
Import	<p>Upload an existing certificate file. Supports Independent Key (requires a matching private key) or PKCS#12 formats.</p> <p>Certificate NameEnter a unique name to identify this certificate in the list.Server/Client CertificateSelect and upload the certificate file (e.g., .cer, .crt, or .pem). The file size must not exceed 100 KB.</p> <p>Key Type</p> <p>Select the format of the certificate being imported:</p> <ul style="list-style-type: none"> • Independent Key: The certificate and private key are in separate files. <p>Private Key: (Required) Select and upload the matching private key file.</p> <p>Private Key Password: (Optional) Enter the password if the private key file itself is encrypted.</p> <ul style="list-style-type: none"> • PKCS#12: The certificate and private key are bundled into a single encrypted file (usually .p12 or .pfx). <p>Password: (Required) Enter the password used to encrypt the PKCS#12 bundle. This is necessary to extract the certificate and key during the import process.</p>
Export	<p>Select a certificate from the list to download its file for backup or external use.</p>

[CA Certificate]

This list manages root or intermediate certificates used to verify the authenticity of external servers.

Table 67. Description of the buttons

Parameters	Function Introduction
<p style="text-align: center;">Import</p>	<p>Upload a CA certificate provided by a trusted authority.</p> <p>Certificate Name Enter a unique alias to identify this CA certificate in the management list.</p> <p>CA Certificate Click to select and upload the CA certificate file (typically in <code>.cer</code>, <code>.crt</code>, or <code>.pem</code> format).</p>

[List Fields]

Table 68. Description of the buttons

Parameters	Function Introduction
<p style="text-align: center;">Certificate Name / Issued on / Expires on</p>	<p>Basic identity and validity details.</p>
<p style="text-align: center;">Status</p>	<p>Shows Normal or Expired.</p>
<p style="text-align: center;">Used by</p>	<p>Lists active modules using the certificate (e.g., HTTPS, Alarm Server).</p>
<p style="text-align: center;">Operation</p>	<p>Check: View detailed properties (Issuer, Subject, Serial Number, etc.).</p> <p>Delete: Remove a certificate.</p> <p> Note: Server/Client Certificates currently "in use" cannot be deleted.</p>

About

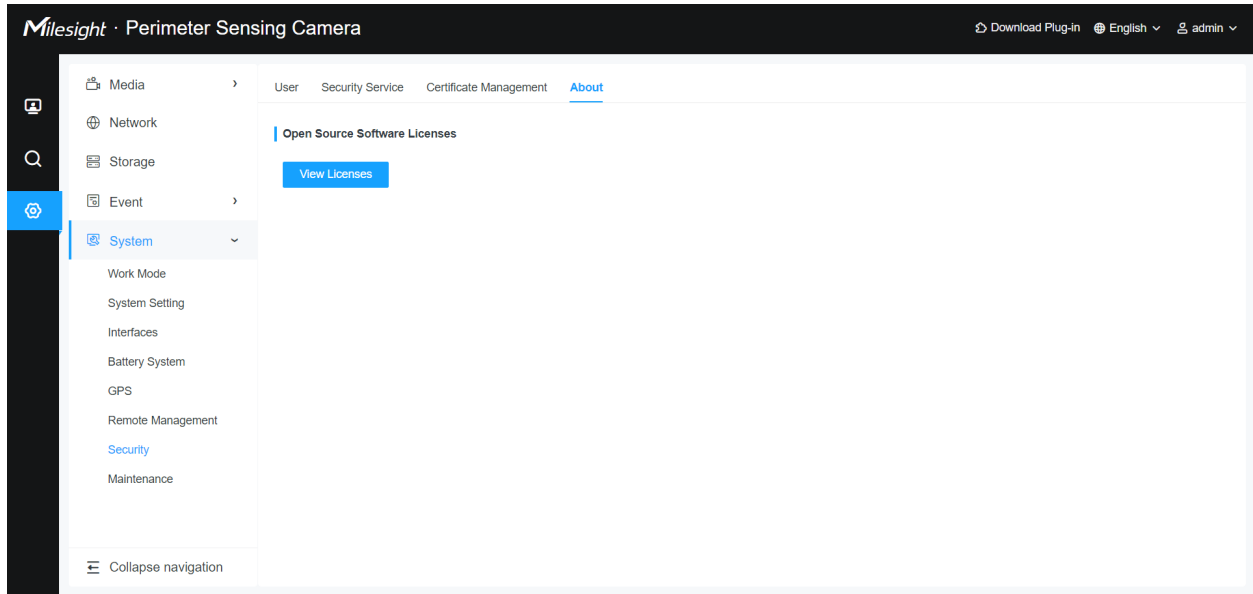

User can view some open source software licenses about the camera by clicking the View Licenses button.

Maintenance

System Maintenance

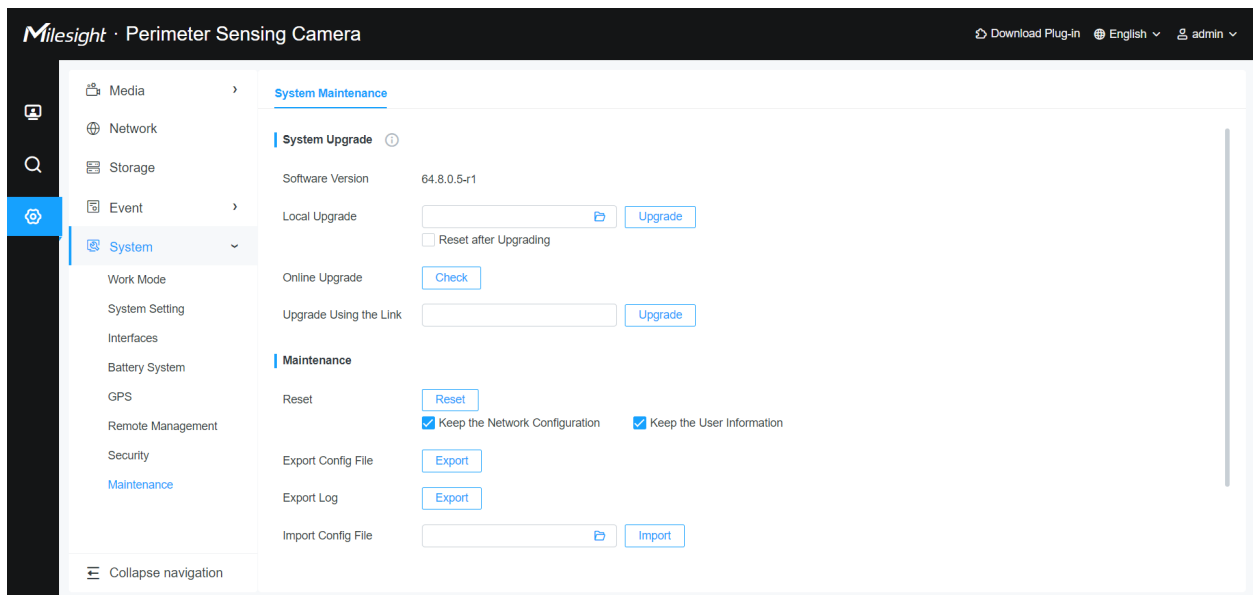
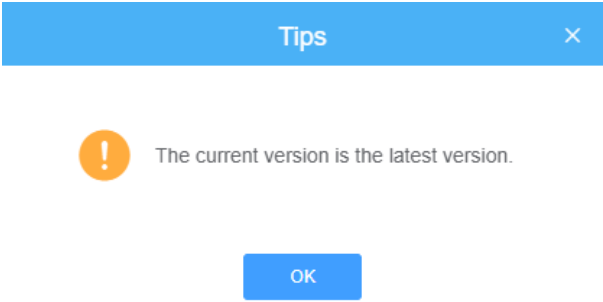





Table 69. Description of the buttons

Parameters	Function Introduction
<p style="text-align: center;">System Upgrade</p>	<p>Software Version: The software version of the camera.</p> <p>Local Upgrade: Click the "Browse" button and select the upgrading file, then click the "Upgrade" button to upgrade. After the system reboots successfully, the update is done.</p> <p>You can check "Reset after Upgrading" to reset the camera after upgrading it.</p> <p>Online Upgrade: Click the "Check" button to check the current latest firmware version on our website, and then click "OK" to upgrade to this version.</p> <p>It will prompt "The current version is the latest version" if your camera is already the latest version.</p> <div style="text-align: center;">  </div> <p> Note: Do not disconnect the power of the device during the update. The device will be restarted to complete the upgrading.</p>

Parameters	Function Introduction
<p style="text-align: center;">Maintenance</p>	<p>Reset: Click "Reset" button to reset the camera to factory default settings.</p> <p>Keep the IP Configuration: Check this option to keep the IP configuration when resetting the camera.</p> <p>Keep the User information: Check this option to keep the user information when resetting the camera.</p> <p>Export Config File: Click this button and a window will pop up as shown below:</p> <div data-bbox="605 604 1403 932" style="border: 1px solid #ccc; padding: 10px; background-color: #f9f9f9;"> <div style="background-color: #0070c0; color: white; padding: 5px; display: flex; justify-content: space-between; align-items: center;"> File Encryption Configuration × </div> <div style="padding: 10px;"> <p>Input the encryption password <input style="width: 100%;" type="text"/></p> <p>Confirm <input style="width: 100%;" type="text"/></p> <div style="display: flex; justify-content: center; gap: 20px; margin-top: 10px;"> Save Cancel </div> </div> </div> <p>You need to enter and confirm password again, then click save button to export configuration file.</p> <p>Export Log: Click this button to export logs and system information of the device operation status.</p> <p> Note: The file format is ".txt".</p> <p>Import Config File: Click this button, then a window will pop up and you can click "OK" to update the configuration.</p> <p>It will pop up a window to prompt "Input the password of config file" , then enter password and click save button to import configuration file.</p> <div data-bbox="605 1329 1403 1587" style="border: 1px solid #ccc; padding: 10px; background-color: #f9f9f9;"> <div style="background-color: #0070c0; color: white; padding: 5px; display: flex; justify-content: space-between; align-items: center;"> File Encryption Configuration × </div> <div style="padding: 10px;"> <p>Input the encryption password <input style="width: 100%;" type="text"/></p> <div style="display: flex; justify-content: center; gap: 20px; margin-top: 10px;"> Save Cancel </div> </div> </div> <p> Note:</p> <p>Export and import the same configuration file. Password must be the same.</p>

Parameters	Function Introduction
Reboot	<p>This function allows you to perform a controlled system restart. Rebooting is often necessary after critical configuration changes (such as Work Mode switching or Certificate updates) or as a troubleshooting step to refresh system services.</p> <p>Click the [Reboot] button to initiate the restart process.</p>

Chapter 10. Services

Milesight provides customers with timely and comprehensive technical support services. End-users can contact your local dealer to obtain technical support. Distributors and resellers can contact directly with Milesight for technical support.

Technical Support Mailbox: support@milesight.com

Web: <http://www.milesight.com>

Online Problem Submission System: <http://www.milesight.com/service/feedback.asp>

MILESIGHT CHINA

TEL: +86-592-5922772

Add: Building C09, Software Park Phase III, Xiamen 361024, Fujian, China